



1954 OFFICIAL NCAA
WRESTLING

\$1

Guide

Ned Blass
Oklahoma A & M

The Official Rules Book and Record Book of the
NATIONAL COLLEGIATE ATHLETIC ASSOCIATION

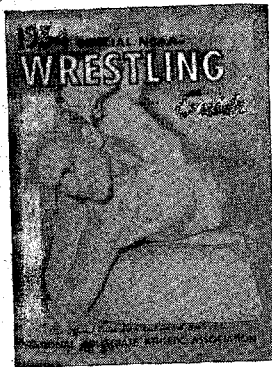

ON THE COVER: Ned Blass, 177-pound National Collegiate champion as a sophomore at Oklahoma A&M in 1953. The brilliant young grappler hails from Ponca City, Okla., where he starred as both a footballer and wrestler in high school. Only moderately fast, Blass is a master of leverage, and is said never to make the same mistake twice.

PUBLISHED BY: The National Collegiate Athletic Association, under the supervision of its Publications Committee:

Ralph Furey, Columbia University, *Chairman*
Asa S. Bushnell, Eastern College Athletic Conference
James W. Liebertz, U.S. Merchant Marine Academy

PRODUCED AND DISTRIBUTED BY: The official service organization of the NCAA, the National Collegiate Athletic Bureau:

Homer F. Cooke, Jr., *Managing Editor*
Steve Boda, Jr., *Research Editor*
Thomas F. Callahan, *Associate Editor*
Marie Montana, *Production Manager*
W. W. Kerswill, *Sales Manager*

ADDRESS ALL CORRESPONDENCE TO: The National Collegiate Athletic Bureau, Box 757, Grand Central Station, New York 17, N. Y., on editorial and sales matters. Permission to reprint material appearing in *The Official NCAA Wrestling Guide*, either wholly or in part, in any form whatsoever, must be secured in writing from the publisher.

ADVERTISING REPRESENTATIVES: Don Spencer Company, Inc., 271 Madison Avenue, New York 16, N. Y.

COPYRIGHT, 1953, BY THE NATIONAL COLLEGIATE ATHLETIC ASSOCIATION
PRINTED IN THE UNITED STATES OF AMERICA

Longines

THE WORLD'S MOST HONORED WATCH

WINNER OF 10 WORLD'S FAIR
GRAND PRIZES, 28 GOLD MEDALS

TRACK AND FIELD

AMERICAN POWER BOAT ASSN.

SWIMMING

FOOTBALL BASKETBALL BOXING

NATIONAL AERONAUTIC ASSN.

OFFICIAL WATCH
FOR TIMING
CHAMPIONSHIP SPORTS EVENTS
IN ALL FIELDS

LONGINES WITTAUER

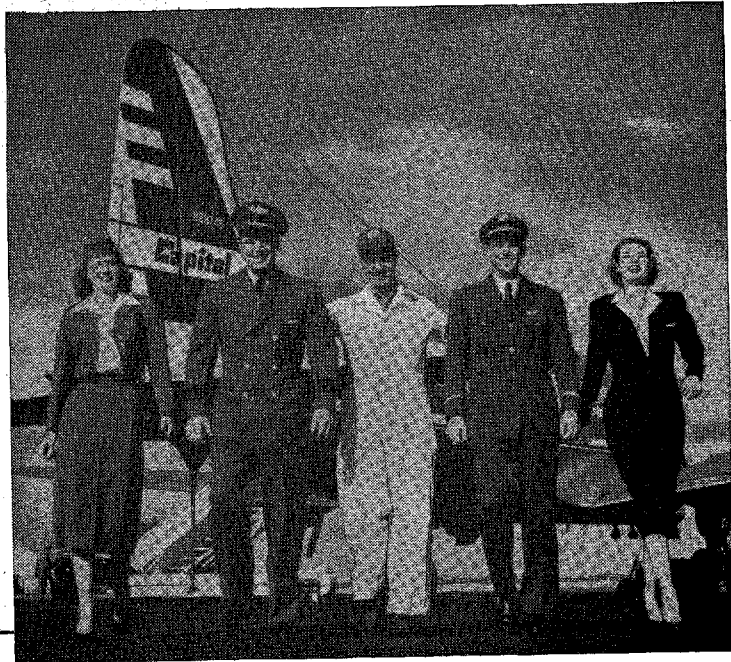

**A TEAM
YOU CAN
COUNT
ON!**

Capital has plenty of know-how . . . over 26 years experience as one of the Nation's leading Scheduled Airlines. For individual or group travel anywhere in the world, call your local Capital representative, or write Mr. J. O. Urquhart, Capital Airlines, National Airport, Washington 1, D. C.



GENERAL OFFICES:
WASHINGTON 1, D. C.

Capital
AIRLINES

Contents

	PAGE
1953 OFFICERS OF THE NCAA	10
NATIONAL COLLEGIATE CHAMPIONSHIPS	13
<i>by Jim Coogan</i>	
COLLEGIATE REVIEWS:	
EASTERN INTERCOLLEGIATE TOURNAMENT	19
NEW ENGLAND INTERCOLLEGIATE TOURNAMENT	20
PA. STATE TEACHERS COLLEGE CONFERENCE TOURNAMENT	21
SOUTHEASTERN TOURNAMENT	23
SOUTHERN CONFERENCE TOURNAMENT	24
MASON-DIXON CONFERENCE TOURNAMENT	25
BIG TEN CONFERENCE TOURNAMENT	27
MID-AMERICAN CONFERENCE TOURNAMENT	27
MIDWEST CONFERENCE TOURNAMENT	28
IIAC TOURNAMENT	30
BIG SEVEN CONFERENCE TOURNAMENT	31
ROCKY MOUNTAIN CONFERENCE TOURNAMENT	33
PACIFIC COAST INTERCOLLEGIATE TOURNAMENT	34
CANADIAN INTERCOLLEGIATE WRESTLING TOURNAMENT	35
1953 DUAL MEET RECORDS	36
SCHOLASTIC REVIEWS:	
CALIFORNIA	37
COLORADO	38
ILLINOIS	38
IOWA	39
KANSAS	39
MARYLAND	40
MICHIGAN	40
MID-SOUTH WRESTLING TOURNAMENT	41
MISSOURI	42
NEW ENGLAND	43
WESTERN NEW ENGLAND	44
NEW JERSEY	45
OKLAHOMA	45
OREGON	46
UTAH	47
VIRGINIA	48
WISCONSIN	49
ACADEMY SCHOOL TOURNAMENT	49
WYOMING	50
RULES SECTION:	
NCAA WRESTLING RULES COMMITTEE	52
OFFICIAL NCAA WRESTLING RULES 1954	53
PENALTY CHART	74
WRESTLING OFFICIALS' SIGNALS	82
HIGH SCHOOL WRESTLING RULES	87
INDEX TO RULES	88

Wilson Sporting Goods Co., Chicago
 Branch Offices in New York,
 San Francisco and 26 other principal cities.
 (A subsidiary of Wilson & Co., Inc.)

Football, Basketball, Baseball, Track, Golf, Tennis, Boxing and many others

IT'S
Wilson
 TODAY
 IN SPORTS
 EQUIPMENT

COACHES!

NEW AMAZING OFFER

PRESENTATION PANEL		
HOME	VISITORS	
21	14	
DOWN	QUARTER	TO GO
1	3	10

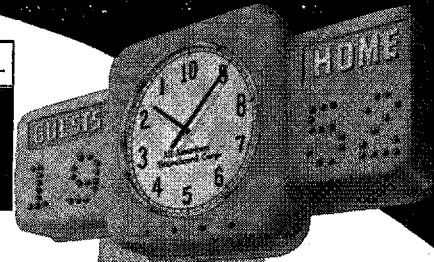

PRE-FAB FOOTBALL SCOREBOARDS

First and only Pre-fab Scoreboards. Function-engineered for economic installation. From \$750 complete.

STRUCTURAL PLASTIC BASKETBALL SCOREBOARDS

Royalite introduced for first time adds striking modern beauty. From \$350 complete.

SCOREBOARDS

of **TOMORROW**

Revolutionary designs with exclusive patented control. New low prices.

FOR YEARS FIRST IN AMERICA

FREE! Special Offer!

You can save up to \$100 on these scoreboards. No obligation.

WRITE FOR INFORMATION TODAY!

ALL-AMERICAN SCOREBOARD CORP.

271 MADISON AVENUE,
 New York 16, N. Y.

All prices f.o.b. Pardeeville, Wis. and subject to change without notice.

Official NCAA Guides



The Official Rules Books
AND RECORD BOOKS
of College Athletics

GUIDES NOW AVAILABLE

List price \$1.00

- | | |
|--------------------|-----------------|
| 1953 Track & Field | 1954 Basketball |
| 1953 Lacrosse | 1954 Wrestling |
| 1953 Football | 1954 Boxing |
| 1953 Soccer | 1954 Ice Hockey |
| 1954 Swimming | |

ADVANCE PUBLISHING SCHEDULE

List price \$1.00

Title	Publication Date
Official 1954 Track & Field Guide	Jan. 1954
Official 1954 Lacrosse Guide	Mar. 1954
Official 1954 Football Guide	June 1954
Official 1954 Soccer Guide	Aug. 1954
Official 1955 Basketball Guide	Sept. 1954
Official 1955 Swimming Guide	Oct. 1954
Official 1955 Wrestling Guide	Oct. 1954
Official 1955 Boxing Guide	Oct. 1954
Official 1955 Ice Hockey Guide	Oct. 1954

A SPECIAL PRINTING

Preliminary editions of the football and basketball rules are printed in handbook form to fill early needs, pending release of the Football and Basketball Guides, which are the official collegiate rules books. Since the handbooks are not stock items, all orders must be placed prior to publication dates. List price 50¢.

Code	Title	Publication Date
FH54	1954 Football Handbook	Apr. 1954
BH55	1955 Basketball Handbook	June 1954

ALWAYS AVAILABLE

Official NCAA
Basketball Scorebook
List price \$1.50

THE NATIONAL COLLEGIATE ATHLETIC BUREAU
Box 757, Grand Central Station New York 17, N. Y.

"The Choice of those
who play the Game"

MacGregor
GoldSmith
SPORTS EQUIPMENT

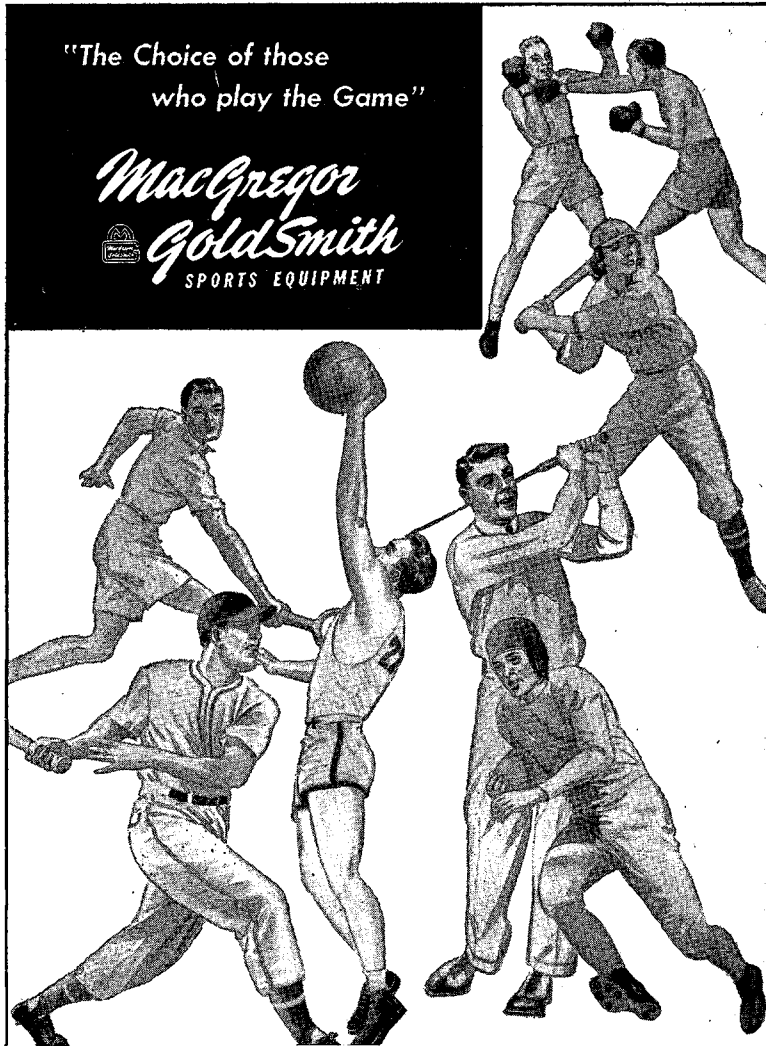

MACGREGOR GOLDSMITH INC., CINCINNATI, OHIO, U. S. A.

1953 Officers of the NCAA

PRESIDENT

A. B. Moore, University of Alabama

SECRETARY-TREASURER

Earl S. Fullbrook, University of Nebraska

EXECUTIVE DIRECTOR

Walter Byers, Fairfax Building, Kansas City, Mo.

PRESIDENT-EMERITUS

Hugh C. Willett, University of Southern California

THE COUNCIL

President and Secretary

Vice-Presidents:

- 1st District—Director William H. McCarter, Dartmouth College
- 2nd District—Director T. J. Hamilton, University of Pittsburgh
- 3rd District—Prof. C. P. Miles, Virginia Polytechnic Institute
- 4th District—Prof. Ralph W. Aigler, University of Michigan
- 5th District—Prof. Frank Gardner, Drake University
- 6th District—Prof. Edwin D. Mouzon, Southern Methodist University
- 7th District—Prof. King Hendricks, Utah State College
- 8th District—Prof. H. P. Everest, University of Washington

Members at Large:

- Rev. Wilfred H. Crowley, University of Santa Clara
- Director Paul F. Mackesey, Brown University
- Prof. Fred Lewis, Vanderbilt University
- Director J. H. Nichols, Oberlin College
- Director J. Shober Barr, Franklin and Marshall College
- Prof. George D. Small, University of Tulsa
- Prof. D. W. Williams, Texas A&M College

EXECUTIVE COMMITTEE

President and Secretary

- T. J. Hamilton, University of Pittsburgh
- William H. McCarter, Dartmouth College
- Wilbur C. Johns, University of California at Los Angeles
- Ralph Furey, Columbia University
- Reaves E. Peters, Missouri Valley Intercollegiate Athletic Assn.
- Howard Grubbs, Southwest Conference
- Bernie H. Moore, Southeastern Conference

*the best
is even
better!*

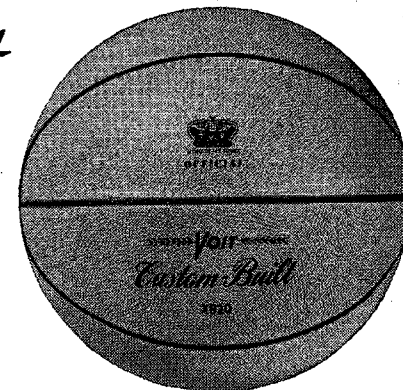

THE NEW Voit XB20 Basketball
*is proving to top coaches and players every
day that the only difference between
the XB20 and the conventional ball
is Voit's 3 to 6 times longer wear!*

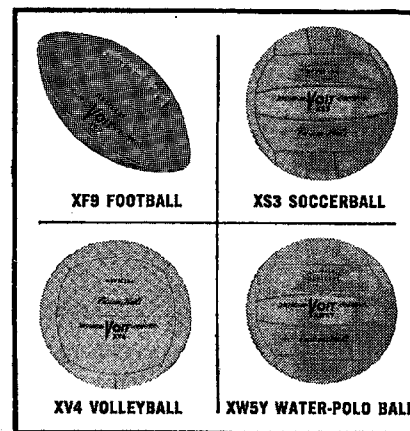

**SEE THE NEW XB20
AT YOUR VOIT DEALER**

Voit top grade athletic equipment is recognized by the rules books for official inter-school competition.



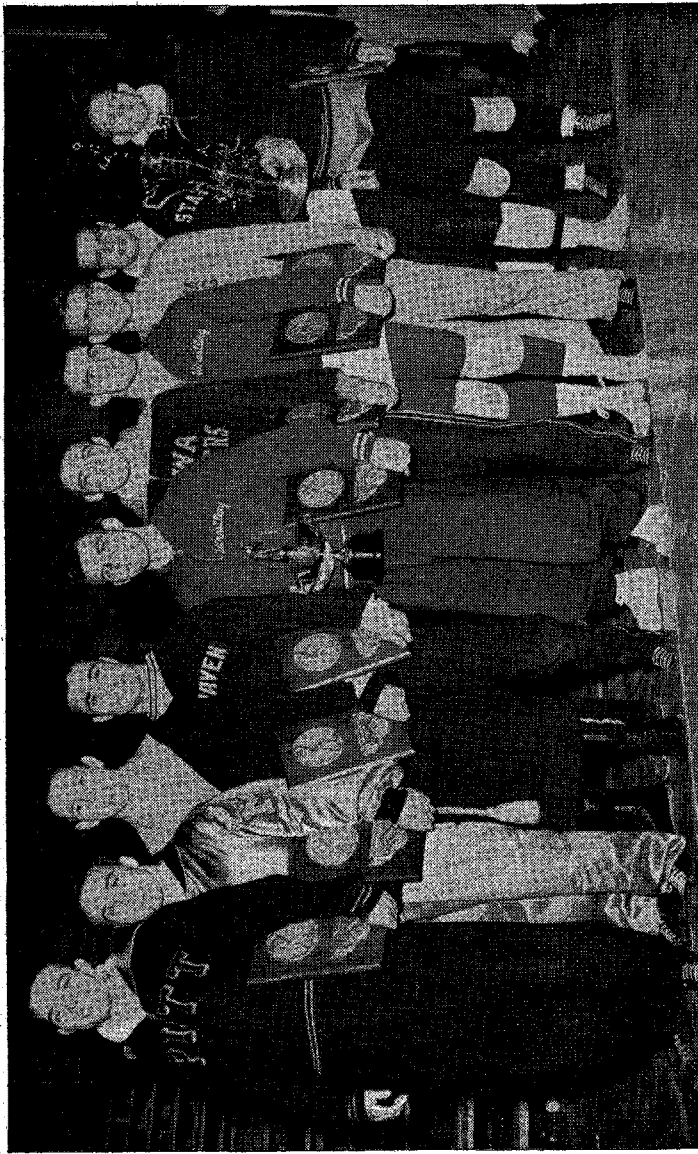

1953 NATIONAL COLLEGIATE WRESTLING CHAMPIONS: Left to right—Hugh Peery (Pittsburgh); Dick Mueller (Minnesota); Leonard DeAugustino (Lock Haven State); Frank Bettucci (Cornell); Jim Harmon (Iowa Teachers); Don Dickason (Cornell); Ned Blass (Oklahoma A&M); Hud Samson (Penn State); Dan McNair (Auburn).

National Collegiate Championships

By JIM COOGAN
 Director, Penn State Sports Information

For the first time in 23 years of tournament competition, the National Collegiate wrestling championship belongs to the East. Charlie Speidel's Penn State matmen, unbeaten since 1950 and three times Eastern champions, deposed Oklahoma in the 1953 tourney at State College, Pa., March 27-28.

Virtually every record of the tournament was shattered as the host team rolled up 21 points to 15 for runner-up Oklahoma. There were 208 matches, 127 on opening day, as entries reached an all-time high of 166. Attendance at the four sessions climbed to a new high of 15,000.

The East, which waited until 1951 to cop more than one individual title and until 1952 to gain three, walked off with five individual crowns as Cornell took two, Pittsburgh, Penn State and Lock Haven State one each.

Only one of three defending titlists—Hugh Peery, Pittsburgh 115-pounder—retained his crown as Joe Lemyre, Penn State's 167-pounder and Gene Nicks, Oklahoma A&M heavyweight, were defeated. Even the outstanding wrestler award came to the East when Frank Bettucci, Cornell 147-pounder, was accorded this distinction.

Cornell's Don Dickason, who had eliminated Joe Lemyre in the semi-final round, clinched the team title for Penn State when he won a referee's decision over Oklahoma's Frank Marks in the 167-pound final. But it remained for Hud Samson, Lion 191-pounder, to set off the celebration when he pinned his opponent in the next-to-last bout on Saturday night's card. An overflow crowd of 6,000 was on hand for the final session.

INDIVIDUAL CHAMPIONS AND PLACE WINNERS

Class	Champion	Second	Third	Fourth
115-lb.	Peery (Pittsburgh)	Christensen (Northwestern)	Meeks (Illinois)	Half (F&M)
123-lb.	Mueller (Minnesota)	D. Reece (Oklahoma)	McCarron (Iowa Tchr)	Lee (Harvard)
130-lb.	Nalan (Michigan)	R. Lemyre (Penn State)	Howard (Ithaca)	Casalichio (Mich. State)
137-lb.	DeAugustino (Lock Haven)	Compton (Illinois)	Maurey (Penn State)	Scott (Oklahoma)
147-lb.	Bettucci (Cornell)	Hoke (Mich. State)	Don Frey (Penn State)	Uram (Pittsburgh)
157-lb.	Harmon (Iowa Tchr.)	Sniff (Colo. A&M)	Eagleton (Oklahoma)	Perrone (Mich. State)
167-lb.	Dickason (Cornell)	Marks (Oklahoma)	J. Lemyre (Penn State)	Eastham (Brown)
177-lb.	Blass (Okla. A&M)	Paulekas (Army)	Wirds (Iowa State)	Lanzi (Toledo)
191-lb.	Samson (Penn State)	Weber (West Chester)	Torio (Toledo)	Gatto (Iowa Tchr.)
Hvywt.	McNair (Auburn)	Nicks (Okla. A&M)	Kraemer (Pittsburgh)	Ellena (UCLA)

TEAM SCORING

Penn State 21, Oklahoma 15, Cornell 13, Oklahoma A&M 11, Iowa Teachers 11, Pittsburgh 9, Michigan 8, Michigan State 7, Minnesota 7, Lock Haven State 6, Illinois 6, Colorado A&M 6, Northwestern 5, Army 5, West Chester State 5, Toledo 4, Brown 3, UCLA 3, Ithaca 2, Iowa State 2, Washington State 2, Colorado 1, Columbia 1, Indiana 1, Lehigh 1, Franklin & Marshall 1, Harvard 1, Syracuse 1.

National Championship Tournament Results

115-Pound Class

First Round—Helf (F&M) defeated Shehigian (Mich. State) 3-2; Peery (Pittsburgh) defeated Mceks (Illinois) 9-4; Christensen (Northwestern) defeated McLain (Oregon State) 6-2; Cramp (Penn State) defeated Jackson (Arkansas St.) 3-0.

Second Round—Christiansen pinned Cramp in 5:01; Peery defeated Helf, 6-2; Dawkins (Ursinus) defeated Ofsthun (Minnesota) 6-5; Whelan (Southern Ill.) defeated Custer (Lock Haven) 9-5.

Semi-Final Round—Peery defeated Dawkins, 11-1; Christensen defeated Whelan, 4-2.

Final Round—Peery defeated Christiansen, 5-1. Consolation—Meeks defeated Helf, 7-2.

123-Pound Class

First Round—Boda (Cornell) defeated Matsumoto (Illinois) referee's decision; McCarron (Iowa Tchr.) defeated Karnes (Army) 4-2; Hockley (Wyoming) defeated Stubblebine (Springfield) 4-3; Crancer (Arkansas St.) defeated Homan (Penn State) 10-2.

Second Round—D. Reece (Oklahoma) pinned Bredehoft (Cornell Col.) in 8:45; Mancuso (Kansas State) defeated Boda, 6-0; Herschend (Northwestern) defeated McCord (Lehigh) 6-4; Crancer defeated Wilson (BYU) 8-1; Hockley defeated Gibson (Wash. State) 4-0; McCarron defeated Boyko (Toledo) 4-2; Mueller (Minnesota) defeated Lobaugh (Okla. A&M) 3-0.

Third Round—Lee defeated Hockley, 4-2; McCarron defeated Herschend, 5-4; D. Reece pinned Mancuso in 5:34; Mueller defeated Crancer, 5-2.

Semi-Final Round—D. Reece defeated McCarron, 3-0; Mueller defeated Lee, 7-1.

Final Round—Mueller pinned D. Reece in 4:45. Consolation—McCarron defeated Lee, 3-2.

130-Pound Class

First Round—Faust (Lehigh) pinned Motley (VPI) in 5:13; R. Lemyre (Penn State) pinned Casalicchio (Mich. State) in 0:49; Leffler (Toledo) defeated Downey (Auburn) 11-4; Nalan (Michigan) pinned Williams (So. Dak. St.) in 7:11; Datteri (Colo. A&M) defeated Robinson (San Diego St.) 12-3; Howard (Ithaca) defeated Duggan (Iowa) 8-2; Long (Colorado) pinned Rollins (BYU) in 7:58.

Second Round—Nalan defeated Leffler, 7-2; Datteri pinned Faust in 8:16; H. Reece (Oklahoma) pinned Long in 4:22; R. Lemyre defeated Howard, 6-5.

Semi-Final Round—Nalan defeated Datteri, 7-4; R. Lemyre defeated H. Reece, referee's decision.

Final Round—Nalan defeated R. Lemyre, 7-5. Consolation—Howard defeated Casalicchio, 2-1.

137-Pound Class

First Round—Jordan (BYU) defeated Hairston (Lincoln) 6-1; Matthews (Pittsburgh) defeated Sterner (Iowa Tchr.) 12-5.

Second Round—Maurey (Penn State) defeated Ruzic (Iowa State) 3-1; DeAugustino (Lock Haven) defeated Austin (Arkansas St.) 11-1; Scott (Oklahoma) defeated Kaul (Michigan) 6-5; Jordan defeated Murray (Cornell Col.) 7-2; Duncan (Wash. State) pinned Woodward (Colo. A&M) in 8:03; Compton (Illinois) defeated Matthews, 9-3;

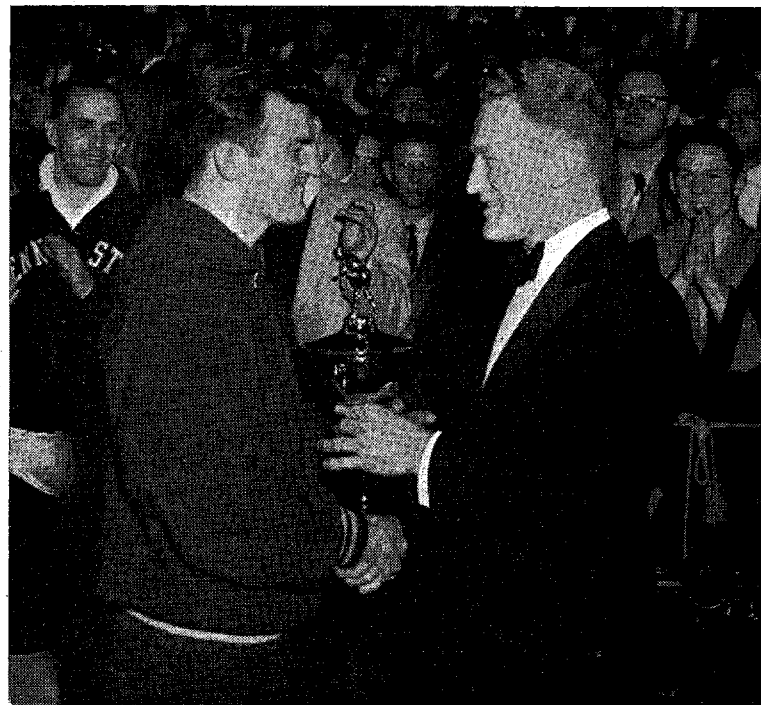

OUTSTANDING WRESTLER AWARD is presented to Cornell's Frank Bettucci by Raymond E. Sparks, Springfield College coach, at the conclusion of the 1953 National Collegiate Championships. He won 147-pound laurels.

Norris (Maryland) defeated Blegen (Mankato St.) 8-6; Thompson (Okla. A&M) defeated Miller (Toledo) 5-1.

Third Round—Scott defeated Jordan, 7-0. Compton defeated Duncan, 7-0; DeAugustino defeated Maurey, 4-2; Thompson defeated Norris, 4-3.

Semi-Final Round—DeAugustino defeated Scott, 9-6; Compton defeated Thompson, 5-0.

Final Round—DeAugustino defeated Compton, 3-1. Consolation—Maurey defeated Scott, 10-2.

147-Pound Class

First Round—Bettucci (Cornell) defeated DePranger (Cornell Col.) 8-2; Scandura (Michigan) pinned Midea (Lock Haven) in 5:02; Rayburn (Oklahoma) defeated Garland (Indiana) 9-0.

Second Round—Uram (Pittsburgh) defeated Elwood (Northwestern) 6-0; Bettucci pinned Ballinger (Wyoming) in 5:14; MacEwan (Kent State) defeated Scandura, 6-4; Don Frey (Penn State) defeated Bains (Auburn) 6-1; Brown (VMI) defeated Speck (BYU) 7-0; Morris (Iowa Tchr.) defeated Rayburn, 6-3; Hoke (Mich. State) defeated Carothers (Lincoln) 10-3; Tittsworth (Okla. A&M) defeated Lockwood (Colo. A&M) 2-1.

Third Round—Morris pinned Brown in 5:33; Don Frey defeated MacEwan, 6-0; Bettucci defeated Uram, 5-3; Hoke defeated Titsworth, referee's decision.

Semi-Final Round—Bettucci defeated Don Frey, 7-3; Hoke defeated Morris, 3-0.

Final Round—Bettucci defeated Hoke, 6-3. Consolation—Don Frey defeated Uram, referee's decision.

157-Pound Class

First Round—Don Frey (Penn State) defeated Bock (Springfield) 8-0; Streyer (Okla. A&M) defeated Tebben (Army) 6-4; Eagleton (Oklahoma) defeated Miller (Cornell Col.) 4-0; Rooney (Syracuse) pinned Whitehill (Lock Haven) in 4:47; Ellis (Indiana) defeated Rumsfeld (Princeton) 6-4; Mahoney (Lehigh) defeated Larsen (Iowa State) 4-1; Perrone (Mich. State) defeated Cobbins (Lincoln) 11-2; Harmon (Iowa Tchr.) defeated Turley (Hofstra) 4-0.

Second Round—Ellis won by default over Mahoney; Harmond defeated Perrone, 8-6; Lee (Michigan) defeated Kramer (Kansas State) 13-9; Fischer (Maryland) defeated Nelson (Wash. State) 7-1; Solomon (Pittsburgh) defeated Arnold (Cornell) 13-7; Rooney defeated Don Frey, 4-3; Sniff (Colo. A&M) pinned Berry (VMI) in 4:04; Eagleton defeated Streyer, 7-1.

Third Round—Solomon defeated Rooney, 9-5; Sniff defeated Eagleton, referee's decision; Ellis defeated Lee, 11-9; Harmon defeated Fischer, 7-5.

Semi-Final Round—Sniff defeated Solomon, 6-1; Harmon defeated Ellis, 3-2.

Final Round—Harmon defeated Sniff, 6-4. Consolation—Eagleton defeated Perrone, 7-2.

167-Pound Class

First Round—Fischer (Maryland) defeated Hockley (Wyoming) 7-4; Marks (Oklahoma) defeated Pankow (Indiana) 6-3; Dickason (Cornell) defeated Nordquist (Illinois) 3-0; McGhee (Wash. State) pinned Loffredo (Iowa Tchr.) in 7:27.

Second Round—Wem (Toledo) defeated Dyer (Springfield) 13-1; Sonneman (Cornell Col.) defeated Chase (Wesleyan) 8-2; J. Lemyre (Penn State) pinned Nowitzky (VMI) in 4:09; Ward (Army) defeated Cooper (Lincoln) 9-0; Marks defeated Lentvorsky (Lock Haven) 6-2; Dickason defeated Eastham (Brown) referee's decision; Fischer defeated Broughton (Colo. A&M) 10-5; Wood (Okla. A&M) defeated McGhee, 6-2.

Third Round—Fischer defeated Wem, 8-2; Marks defeated Sonneman, 3-1; J. Lemyre defeated Wood, 9-2; Dickason defeated Ward, 7-5.

Semi-Final Round—Marks defeated Fischer, referee's decision; Dickason defeated J. Lemyre, referee's decision.

Final Round—Dickason defeated Marks, referee's decision. Consolation—J. Lemyre defeated Eastham, 6-2.

177-Pound Class

First Round—Paulekas (Army) defeated Lanzi (Toledo) 13-4; O'Shaughnessy (Michigan) defeated Dvorozniak (Penn State) 8-1; McCullough (Wyoming) defeated Kelley (Oklahoma) referee's decision; Bob Craig (Lock Haven) defeated Keller (Cornell) 12-8.

Second Round—O'Shaughnessy defeated Shanahan (Maryland) 10-1; Paulekas pinned Lindell (Cornell Col.) in 8:32; Blass (Okla. A&M) defeated McCullough, 5-3; Wirds (Iowa State) defeated Craig, 11-4.

Semi-Final Round—Paulekas defeated O'Shaughnessy, 4-0; Blass defeated Wirds, 16-8.

Final Round—Blass defeated Paulekas, 8-4. Consolation—Wirds defeated Lanzi, 7-2.

191-Pound Class

First Round—Hearon (Oklahoma) defeated MacAleer (Princeton) 7-0; Gatto (Iowa Tchr.) defeated Evans (So. Dak. St.) 6-0; Shining (Iowa) defeated Drake (Maryland) 11-6; Weber (West Chester) defeated Veldman (Minnesota) 6-1; Samson (Penn State) pinned Williams (Oregon State) in 3:40; Torio (Toledo) pinned Hunter (Pittsburgh) in 8:06; Waldon (Iowa State) defeated Stadler (Arkansas St.) 6-5.

Second Round—Weber pinned Hearon in 8:08; Samson defeated Waldon, 6-1; Gatto pinned Shining in 8:41; Torio defeated Sotir (Springfield) 5-0.

Semi-Final Round—Samson defeated Torio, 2-0; Weber defeated Gatto, 5-2.

Final Round—Samson pinned Weber in 4:15. Consolation—Torio defeated Gatto, 3-1.

Heavyweight Class

First Round—Littlefield (Columbia) pinned Wood (Minnesota) in 8:28; Ellena (UCLA) pinned McNicol (VPI) in 5:35; Husmann (Nebraska) defeated Beyer (Syracuse) 6-5.

Second Round—Ellena pinned Littlefield in 0:40; Nicks (Okla. A&M) defeated Kraemer (Pittsburgh) 6-1; McNair (Auburn) defeated Megele (Hofstra) 5-0; Husmann defeated Lloyd (CCNY) 15-5.

Semi-Final Round—Nicks pinned Ellena in 4:59; McNair defeated Husmann, referee's decision.

Final Round—McNair defeated Nicks, referee's decision. Consolation—Kraemer defeated Ellena, 4-3.

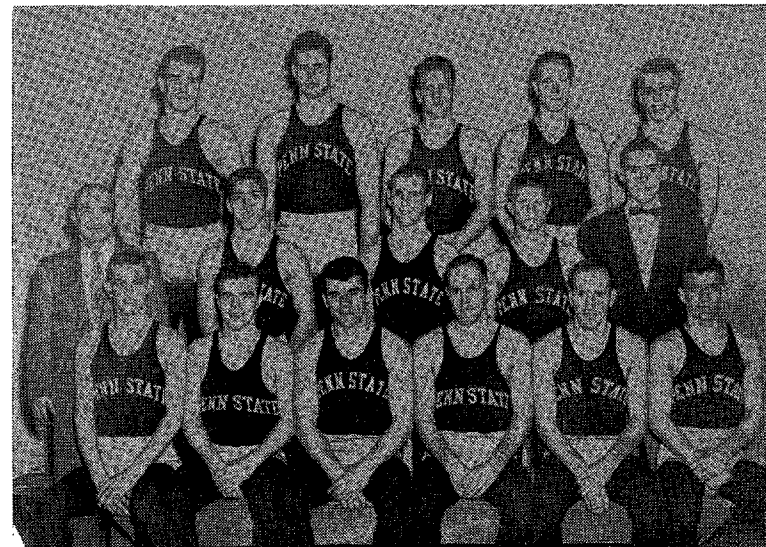

PENN STATE—TEAM MAT CHAMPS: Left to right, front row—Homan, D. Lemyre, J. Lemyre, Don Frey, Doug Frey, Fomicola; second row—Speidel (coach), Cassel, Mawrey, Cramp, Winterburn (manager); third row—Chamberlain, Samson, Shawley, Dvorozniak, Winters.



EASTERN'S INDIVIDUAL TITLISTS: Left to right—Seel (Lehigh) Heavyweight, Paulekas (Army) 177, Dickason (Cornell) 167, Hunt (Cornell) 157, Bettucci (Cornell) 147, Maurey (Penn State) 137, D. Lemyre (Penn State) 130, McCord (Lehigh) 123.

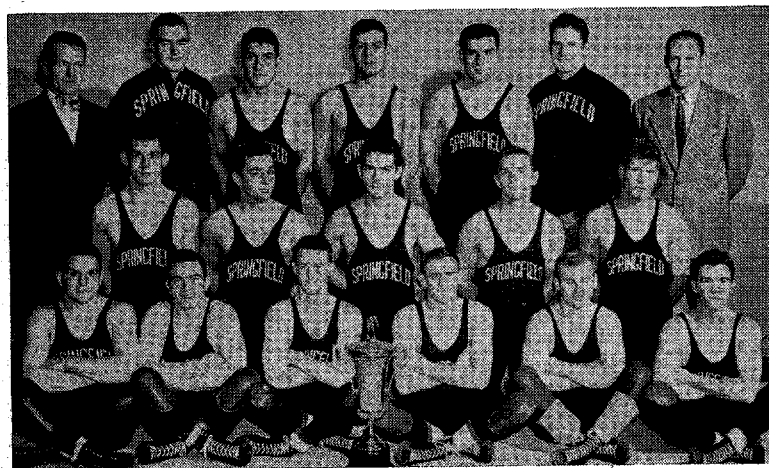

NEW ENGLAND RULERS—SPRINGFIELD COLLEGE: Left to right, front row—Schweghardt, Little, Ross, Coursen (captain), Praskelt, Stubblebine; second row—Chandler, Caramihalis, Dyer, Mulligan, Black; back row—Sparks (coach), Van Vleet (manager), Jones, Cowan, Sotir, Christow, Dunn (asst. coach).

COLLEGIATE REVIEWS

Eastern Intercollegiate Tournament

By **GEORGE L. SHIEBLER**, Eastern College Athletic Conference

For the third consecutive season Penn State College ran off with the team championship honors in the Eastern Intercollegiate Wrestling Association. The Nittany Lions rang up a total of 31 points in the 49th Annual Tournament held in Dillon Gymnasium, of Princeton University on March 13-14.

The pupils of Coach Charles Speidel amassed their point total by annexing championship laurels with Dick Lemyre's successful defense of his 130-pound title and Gerald Maurey's stellar win over Syracuse's DeBellis in the 137-pound division. Don Frey was runner-up to Cornell's Frank Bettucci in the 147-pound class and Joe Lemyre and Hudson Samson were third-place finishers in the 167-pound and heavyweight division, respectively.

The competition saw 128 athletes from 16 member colleges. Cornell with 25 points and a trio of individual champions gave Penn State a stiff battle for team honors. The Big Red garnered the following titles—defendant Bettucci won in the 147-pound class, Ken Hunt grabbed off the 157-pound crown and the 167-pound medal went to Cornell's Don Dickason.

Bettucci was voted "the outstanding performer" award. In the final round McCord pinned John Lee, Harvard, in 8:19; Dick Lemyre, at 130 pounds, pinned DeBellis, Syracuse, in 8:07; at 147 pounds, Bettucci pinned Frey in 4:39; Hunt at 157 pounds defeated Princeton's Don Rumsfeld, 9-5; Dickason won by 8-3 over Jerry Tebben, Army; Alfred Paulekas of Army defeated Peter Blair of Navy for the 177-pound title and Werner Seel of Lehigh gained a 2-1 victory over Dick Bayer of Syracuse for the heavyweight crown.

The 1954 championships are scheduled for March 12 and 13 at Cornell University, Ithaca, N. Y.

INDIVIDUAL CHAMPIONS AND PLACE WINNERS

Class	Champion	Second	Third	Fourth
123-lb.	McCord (Lehigh)	Lee (Harvard)	R. Karnes (Army)	Helf (F&M)
130-lb.	R. Lemyre (Penn State)	Jesser (Navy)	Blackman (Cornell)	Mulligan (Rutgers)
137-lb.	Maurey (Penn State)	DeBellis (Syracuse)	Faust (Lehigh)	MacLean (Brown)
147-lb.	Bettucci (Cornell)	Don Frey (Penn State)	Ferriter (Brown)	J. Karnes (Army)
157-lb.	Hunt (Cornell)	Rumsfeld (Princeton)	Rooney (Syracuse)	Mahoney (Lehigh)
167-lb.	Dickason (Cornell)	Tebben (Army)	J. Lemyre (Penn State)	Eastham (Brown)
177-lb.	Paulekas (Army)	Blair (Navy)	Downey (Yale)	Comly (Lehigh)
Hvywt.	Seel (Lehigh)	Bayer (Syracuse)	Samson (Penn State)	Littlefield (Columbia)

TEAM SCORING

Penn State 31, Cornell 25, Lehigh 22, Army 18, Syracuse 13, Navy 12, Brown 5, Harvard 5, Princeton 5, F&M 4, Temple 4, Columbia 3, Yale 3, Rutgers 2, Pennsylvania 0, Virginia 0.

New England Intercollegiate Tournament

By J. E. BULLOCK, *Williams College*

The annual championship tournament of the New England Intercollegiate Wrestling Association was held at Williams College, Williamstown, Mass., March 13-14.

Springfield successfully defended its title by winning four individual titles to rack up 37 points. Wesleyan was second with 21 and Amherst third with 19.

Chase, Wesleyan's 177 pound titlist, was voted the outstanding wrestler of the tournament and awarded the Coaches Trophy.

The 1954 tournament will be held March 5-6 at Amherst College.

VARSITY CHAMPIONS AND PLACE WINNERS

Class	Champion	Second	Third	Fourth
123-lb.	Stubblebine (Springfield)	D. Tank (Amherst)	Graef (MIT)	Sime (Wesleyan)
130-lb.	Coursen (Springfield)	S. Schellenger (Amherst)	Kennaday (MIT)	King (Coast Guard)
137-lb.	Faucher (Coast Guard)	Williams (Williams)	Schellenger (Amherst)	Little (Wesleyan)
147-lb.	Mulligan (Springfield)	Little (Williams)	Reif (Coast Guard)	Tank (Amherst)
157-lb.	Graham (Wesleyan)	Tulloch (Amherst)	Bock (Springfield)	Gemmill (Williams)
167-lb.	Dyer (Springfield)	Gordon (Williams)	Carroll (Wesleyan)	Kunz (Amherst)
177-lb.	Chase (Wesleyan)	Stryfeler (Coast Guard)	Murphy (Williams)	Jones (Springfield)
Hvywt.	Seymour (MIT)	Sotir (Springfield)	Callahan (Wesleyan)	Fall (Williams)

VARSITY TEAM SCORING

Springfield 37, Wesleyan 21, Amherst 19, Williams 18, Coast Guard 16, MIT 14, Tufts —15, Boston U. —40.

FRESHMAN CHAMPIONS AND PLACE WINNERS

Class	Champion	Second	Third	Fourth
123-lb.	Danielson (Amherst)	Moorehead (Coast Guard)	Irwin (Wesleyan)	Butler (Tufts)
130-lb.	Alisi (Springfield)	Fricke (Wesleyan)	Pitts (Williams)	Smith (Coast Guard)
137-lb.	Gramentine (Wesleyan)	Maurlyz (Williams)	Kalesnik (Springfield)	Andrews (Amherst)
147-lb.	Koster (Williams)	Lawson (MIT)	Steeves (Springfield)	J. White (Amherst)
157-lb.	Madsen (Williams)	Hirschi (MIT)	Flynn (Springfield)	Bloomer (Amherst)
167-lb.	Soobitsky (Springfield)	Becker (MIT)	Disston (Amherst)	Watts (Wesleyan)
177-lb.	Beers (Boston U.)	Mason (Wesleyan)	White (Amherst)	Bristol (Coast Guard)
Hvywt.	Patton (Amherst)	Dunn (Wesleyan)	Kellogg (Coast Guard)	Kamis (Springfield)

FRESHMAN TEAM SCORING

Amherst 26, Wesleyan 24, Williams 23, Springfield 23, MIT 15, Coast Guard 12, Boston U. —16, Tufts —17.

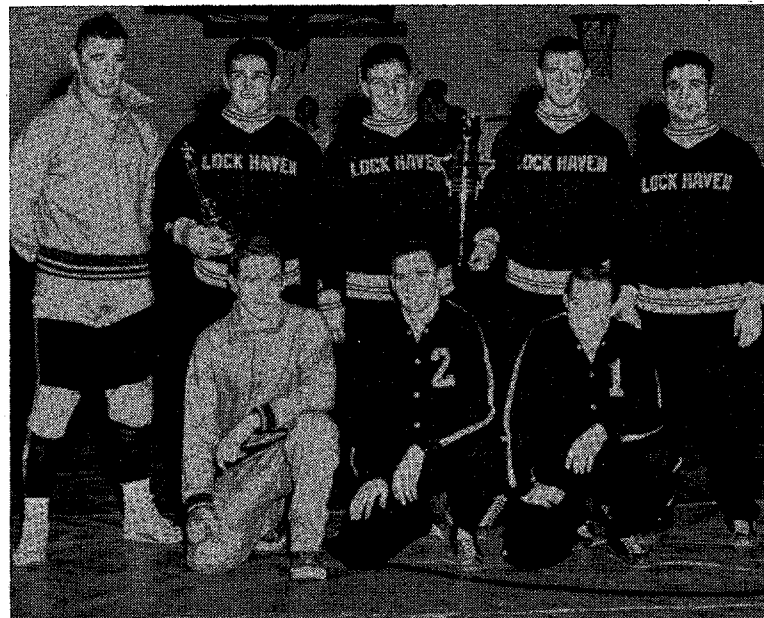

PENN TEACHERS' CROWN WINNERS: Left to right, front row—Whitman (West Chester) 137, Flegal (Millersville) 130, Shervanik (Millersville) 123; back row—Weber (West Chester) heavyweight, Craig (Lock Haven) 177, Lentvorsky (Lock Haven) 167, Whitehill (Lock Haven) 157, DeAugustino (Lock Haven) 147.

Pa. State Teachers College Conference Tournament

By HUBERT JACK, *Sports Publicity, Lock Haven State*

For the eighth time in the 11 years that the Pennsylvania State Teachers College Conference wrestling tournament has been held, Lock Haven State captured the team trophy.

The tournament was held March 6 and 7 at Lock Haven. Although the classic was relatively smaller this year, it was as hard fought as usual.

The team scoring was divided as follows: Lock Haven State 44, West Chester State 32, Millersville State 27, Indiana State 14.

Robert Craig, Lock Haven's 177-pound representative, was voted the most outstanding wrestler of the tournament.

The tournament will be held in West Chester in 1954.

INDIVIDUAL CHAMPIONS

Class	Champion	Class	Champion
123-lb.	Shervanik (Millersville)	157-lb.	Whitehill (Lock Haven)
130-lb.	Flegal (Millersville)	167-lb.	Lentvorsky (Lock Haven)
137-lb.	Whitman (West Chester)	177-lb.	Craig (Lock Haven)
147-lb.	DeAugustino (Lock Haven)	Hvywt.	Weber (West Chester)

Southeastern Tournament

By J. J. MILLER, Coach, Emory University

Auburn successfully defended its team title in the Southeastern Inter-collegiate Wrestling Association championship held at Vanderbilt University's new Memorial Gymnasium.

Auburn, coached by A. W. (Swede) Umbach, scored a total of 55 points and produced seven champions. Middle Tennessee, coached by Joe Black Hayes, was a surprise runner-up with one individual champion and 28 points. Chattanooga, coached by Andy Nardo, tallied 19 points. Vanderbilt, coached by Buford (Baby) Ray, who served as tournament director, scored 18 points for fourth place.

Coach J. A. Davis' Maryville grapplers placed fifth with 18 points and Emory University, under Johnny Miller, was last with 8 points.

INDIVIDUAL CHAMPIONS AND RUNNERS-UP

Class	Champion	Runner-up
115-lb.	Somtherman (Vanderbilt)	Porterfield (Middle Tenn. St.)
123-lb.	David (Auburn)	Leverette (Middle Tenn. St.)
130-lb.	Ray Downey (Auburn)	Gunnels (Auburn)
137-lb.	Long (Middle Tenn. St.)	Day (Vanderbilt)
147-lb.	Bains (Auburn)	Traylor (Emory)
157-lb.	Hudson (Auburn)	Nickens (Middle Tenn. St.)
167-lb.	Sanders (Auburn)	Hix (Middle Tenn. St.)
177-lb.	Dick Downey (Auburn)	
191-lb.	Drake (Chattanooga)	
Hvywt.	McNair (Auburn)	

TEAM SCORING

Auburn 55, Middle Tenn. St. 28, Chattanooga 19, Vanderbilt 18, Maryville 18, Emory 8.

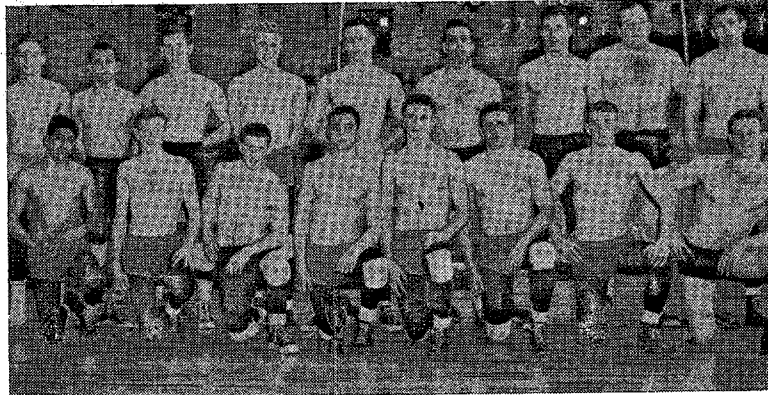

SOUTHEASTERN TOURNEY FINALISTS: Left to right, first row—David (Auburn) 123, R. Downey (Auburn) 130, Long (Middle Tennessee) 137, Bains (Auburn) 147, Hudson (Auburn) 157, Sanders (Auburn) 167, D. Downey (Auburn) 177, Drake (Chattanooga) 191; second row—Somtherman (Vanderbilt) 115, Porterfield (Middle Tennessee) 115, Leverette (Middle Tennessee) 130, Gunnels (Auburn) 137, Day (Vanderbilt) 147, Traylor (Emory) 167, Nickens (Middle Tennessee) 177, Hix (Middle Tennessee) heavyweight, McNair (Auburn) heavyweight.

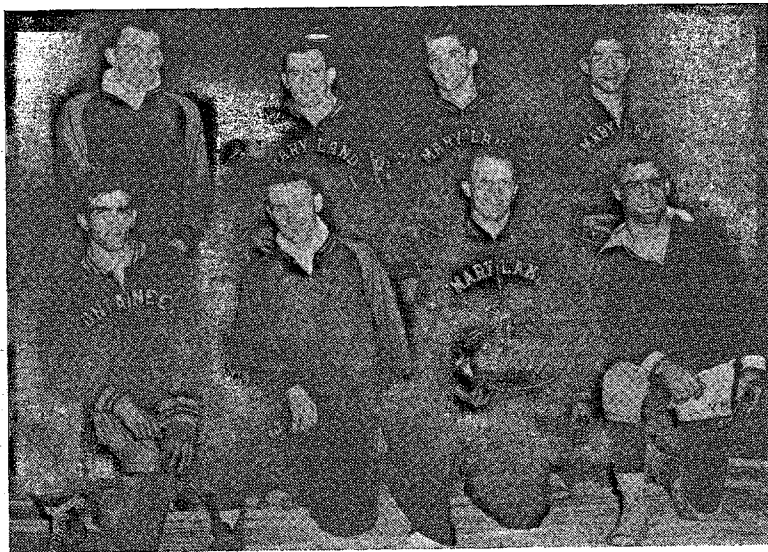

BEST GRAPPLERS IN SOUTHERN LOOP: Left to right, first row—Perry (West Virginia) 123, Motley (V.P.I.) 130, Norris (Maryland) 137, Brown (V.M.I.) 147; second row—McNicol (V.P.I.) heavyweight, Shanahan (Maryland) 177, E. Fischer (Maryland) 167, B. Fischer (Maryland) 157.

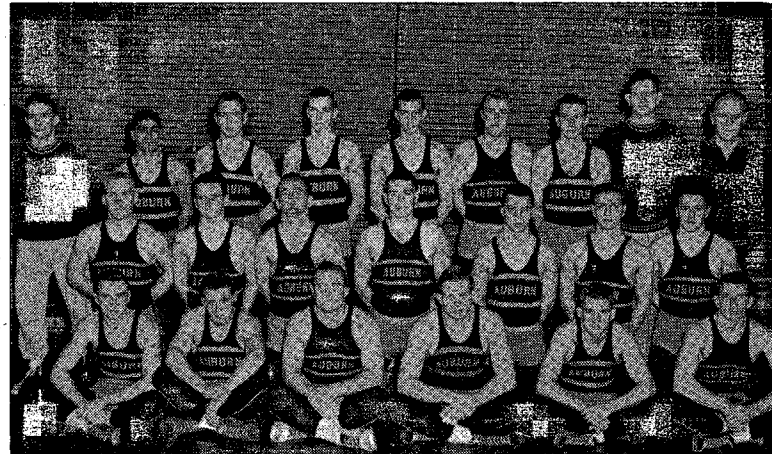

AUBURN—DEEP SOUTH REIGN UNBROKEN: Left to right, front row—Hudson, Sander, Duncan, McNair, Myers, D. Downey; second row—Dodd, Chamblin, Baker, Bloxham, Baines (captain), McDade, Buckshaw; third row—Dragoin (asst. coach), David, Hall, DeLoach, Cotton, Gunnels, R. Downey, McNair (manager) Umbach (coach).

Southern Conference Tournament

By OSCAR W. GUPTON, Virginia Military Institute

The University of Maryland annexed their second straight Southern Conference championship by scoring 40 points to runner-up West Virginia's 23.

The Terps landed four men on the championship pedestal, while West Virginia placed seven of its eight men to gain the runner-up berth.

Rodney Norris, 137-pound champion of Maryland, was nominated the tournament's outstanding wrestler.

Officials of the event, staged at VMI's field house were Carl Kitt of Navy and Howie Davis of Washington & Lee.

INDIVIDUAL CHAMPIONS AND PLACE WINNERS

Class	Champion	Second	Third	Fourth
123-lb.	Perry (West Va.)	Carroll (Maryland)	Ellis (Wash. & Lee)	Raimondo (Duke)
130-lb.	Motley (VPI)	Crowley (Maryland)	Guidi (West Va.)	Barclay (VMI)
137-lb.	Norris (Maryland)	Pritchard (West Va.)	Craven (Davidson)	Burrill (Duke)
147-lb.	Brown (VMI)	Diamond (West Va.)	Buxton (Davidson)	Little (Maryland)
157-lb.	B. Fischer (Maryland)	McSpadden (Wash. & Lee)	A. Gregory (No. Caro.)	Kramer (West Va.)
167-lb.	E. Fischer (Maryland)	Nowitzky (VMI)	Staunton (Wash. & Lee)	Jantzen (Citadel)
170-lb.	Shanahan (Maryland)	Gregory (No. Caro.)	Struble (West Va.)	McCubbin (Wash. & Lee)
Hvywt.	McNicol (VPI)	Campbell (Duke)	Buchanan (West Va.)	Carter (VMI)

TEAM SCORING

Maryland 40, West Virginia 23, VPI 23, VMI 12, Washington & Lee 10, North Carolina 8, Duke 7, Davidson 5, Citadel 2.

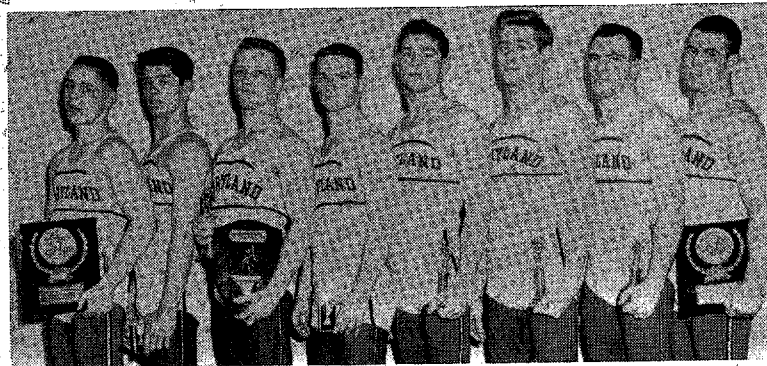

ON SOUTHERN CONFERENCE THRONE—MARYLAND: Left to right, Jerome Carroll, Bob Crowley, Rodney Norris, Danny Little, Bob Fischer, Ernie Fischer, Jack Shanahan, Carl Everley.



MASON-DIXON'S TOP TEAM—BALTIMORE: Left to right, front row—Cohen (manager), Waltemyers, Palmer, Goldin, Millner, Brunner; second row—Pyle (trainer), Toston, Dunn, Doory, Beverly, Shofer, Lohrey (coach).

Mason-Dixon Conference Tournament

By MARSHALL S. TURNER, JR., Johns Hopkins University

Johns Hopkins University was host to the 10th Annual Mason-Dixon Wrestling Championships on February 27 and 28. There were 47 wrestlers, representing 7 schools, who participated in this year's tournament.

The University of Baltimore edged Gallaudet College for the team championship, 33 to 29, and thus retained the crown they won last year. Each had three individual champions, with Towson State Teachers and Loyola College providing the other two. Loyola took third place in the team-standings with 22 points.

Gene Spurrier of Towson State Teachers, and Al Doory of the University of Baltimore were repeat winners in the 123 lb. and 147 lb. classes, respectively. Jack Cyphers, of Loyola, winner last year in the 157 lb. class, moved up one weight to win his championship. Sid Goldin, last year's heavyweight champion from Baltimore, this year won his championship in the 177 lb. class.

INDIVIDUAL CHAMPIONS AND PLACE WINNERS

Class	Champion	Second	Third	Fourth
123-lb.	Sepurrier (Towson)	Hallisey (Catholic)	Shofer (Baltimore)	Idzi (Loyola)
130-lb.	Hoke (Gallaudet)	Ruland (Johns Hopkins)	Toston (Baltimore)	Micale (Catholic)
137-lb.	Brunner (Baltimore)	Weber (Towson)	Burke (Loyola)	Favo (Catholic)
147-lb.	Doory (Baltimore)	Swain (Gallaudet)	Stick (Johns Hopkins)	Kelly (Loyola)
157-lb.	Wright (Gallaudet)	Manderfield (Catholic)	Szczypinski (Johns Hopkins)	Palmer (Baltimore)
167-lb.	Cyphers (Loyola)	Milner (Baltimore)	Shanklin (Western Md.)	Halberg (Gallaudet)
177-lb.	Goldin (Baltimore)	Berlett (Johns Hopkins)	Fallon (Loyola)	Flaherty (Gallaudet)
Hvywt.	Carlson (Gallaudet)	Callahan (Loyola)	Florenzo (Catholic)	Duhl (Western Md.)

TEAM SCORING

Baltimore 33, Gallaudet 29, Loyola 22, Johns Hopkins 16, Catholic 14, Towson 12, Western Maryland 4.

Big Ten Conference Tournament

By CHARLES McDANIEL, Coach, Indiana University

Michigan's well-balanced wrestling squad, scoring in six of the eight weight classes to give its two individual champions ample backing, won the 1953 Big Ten championship by a five-point margin over Michigan State in the two-day meet held at Indiana University, March 6-7.

The Wolverine drive to its first title since 1944, the third under veteran coach Cliff Keen, was sparked by a pair of defending champions, 130-pound Snip Nalan and 177-pounder Dick O'Shaughnessy, whose completion of undefeated seasons and resulting titles accounted for 14 of Michigan's 27-point winning total.

With ten wrestlers entering the tournament with undefeated records, the field was one of the best in recent years. Caliber of the competition can be gauged by the fact that only four of them preserved their unbeaten status by tourney's end—Nalan, O'Shaughnessy, Minnesota's 123-pound champ, Dick Mueller and Michigan State's 157-pound king, Bob Hoke.

Three of the four defending champions extended their domination. Besides Nalan and O'Shaughnessy, Pete Competon, 137-pound titlist of Illinois, came through again, but Northwestern's Jack Herschend failed to repeat.

Toughness of the field was enhanced by presence of two other 1952 champions making bids in different weights. Indiana's Jim Ellis had his two-year undefeated status shattered in the 157-pound final and George Myers of Iowa, saw his perfect record for the season spoiled in the 177-pound final.

Michigan, Minnesota and Michigan State took away two titles each and Illinois and Indiana split the two remaining ones.

INDIVIDUAL CHAMPIONS AND PLACE WINNERS

Class	Champion	Second	Third	Fourth
123-lb.	Mueller (Minnesota)	Moeks (Illinois)	Herschend (Northwestern)	Vega (Purdue)
130-lb.	Nalan (Michigan)	Duggan (Iowa)	Casilfocchio (Mich. State)	Kachiroubas (Illinois)
137-lb.	Compton (Illinois)	Kaul (Michigan)	D. Gunner (Mich. State)	Malcolm (Minnesota)
147-lb.	Pankow (Indiana)	Scandura (Michigan)	Lutz (Illinois)	Ellwood (Northwestern)
157-lb.	Hoke (Michigan State)	Ellis (Indiana)	Lee (Michigan)	Hankins (Purdue)
167-lb.	Perrone (Michigan State)	Sturgus (Northwestern)	Heaton (Iowa)	Rumsey (Michigan)
177-lb.	O'Shaughnessy (Michigan)	Myers (Iowa)	Veldman (Minnesota)	Milligan (Ohio State)
Hvywt.	Wood (Minnesota)	Fowler (Michigan State)	Whitacre (Ohio State)	Shining (Iowa)

TEAM SCORING

Michigan 27, Michigan State 22, Minnesota 17, Illinois 16, Indiana 11, Iowa 11, Northwestern 9, Ohio State 6, Purdue 2, Wisconsin 0.

Mid-American Conference Tournament

For the second successive year Toledo annexed the Mid-American Conference Wrestling Championships, held at Western Reserve University.

The Rocket matmen swept the conference dual meet season by registering decisive wins over all conference foes and placing eight men in the finals of the conference meet.

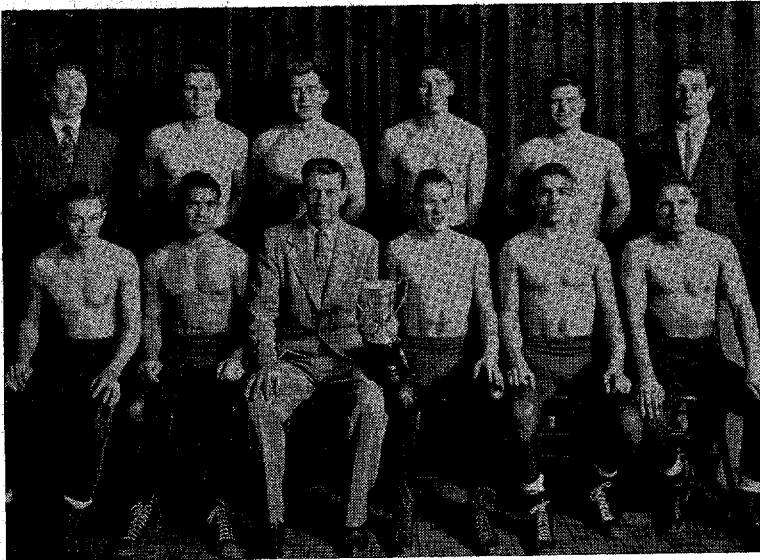

MICHIGAN'S BIG TEN KINGS: Left to right, front row—Joe Atkins, Joe Scandura, Cliff Keen (coach), Snip Nalan, Andy Kaul, Jack Gallow; back row—Del Wright (manager), Bronson Rumsey, Dick O'Shaughnessy, Harold Holt, Miles Lee, Robert Betzig (asst. coach).

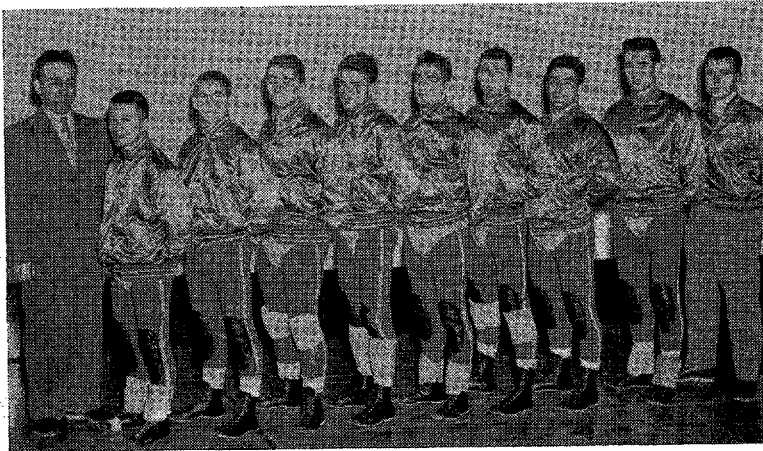

TOLEDO'S MID-AMERICAN VICTORS: Left to right—Joe Scalzo (coach), Steve Kerlin, Dick Leffler, Don Wem, Paul Boyko, Russ Zanzaria, Bill Miller, Dick Torio, Ed Lansi, Eldon Riehm.

Repeating individual champions were: Paul Boyko, Toledo at 137 pounds; Ian McEwan, Kent State, 157 pounds and Don Wem, Toledo, 167 pounds.

INDIVIDUAL CHAMPIONS AND PLACE WINNERS

Class	Champion	Second	Third	Fourth
123-lb.	Worz (Kent State)	Kerlin (Toledo)	Hoskinson (Bowl. Green)	Moley (Western Res.)
130-lb.	Leffler (Toledo)	Campetto (Kent State)	Mogar (Ohio U.)	Williams (Miami, O.)
137-lb.	Boyko (Toledo)	Nellis (Miami, O.)	Twark (Kent State)	Jordan (Western Res.)
147-lb.	Miller (Toledo)	Frate (Miami, O.)	Barry (Kent State)	Hoehn (Ohio U.)
157-lb.	McEwan (Kent State)	Zaccaria (Toledo)	Nelson (Miami, O.)	Leonard (Bowl. Green)
167-lb.	Wem (Toledo)	Carter (Ohio U.)	Sbrocco (Miami, O.)	Bruck (Bowl. Green)
177-lb.	Dubray (Kent State)	Lanzi (Toledo)	Karp (Miami, O.)	Wilson (Ohio U.)
Hvywt.	Torio (Toledo)	Bruneman (Miami, O.)	Durig (Bowl. Green)	Morse (Kent State)

TEAM SCORING

Toledo 46, Kent State 30, Miami (O.) 22, Ohio U. 8, Bowling Green 8, Western Reserve 3.

Midwest Conference Tournament

Cornell College continued its domination of Midwest Conference wrestling with its 15th straight championship at the annual meet ably conducted at Ripon College, Ripon, Wis. Cornell entered six wrestlers and won six titles, with each wrestler adding at least one pin point to the score.

Midwest Conference coaches customarily concede the team championship to Cornell and the fight is for second place. That was the case again this year as Cornell scored 45 points and the rest of the teams were closely bunched. Grinnell was second with 19 points and Coe was third with 16.

INDIVIDUAL CHAMPIONS AND PLACE WINNERS

Class	Champion	Second	Third	Fourth
123-lb.	Bredahoff (Cornell)	Robertson (Coe)	Lysne (St. Olaf)	Higa (Grinnell)
130-lb.	Klepfer (Carleton)	Ihsen (Ripon)	Johnson (Grinnell)	Becker (St. Olaf)
137-lb.	Murray (Cornell)	Couve (Grinnell)	Kinnaird (Carleton)	Hybl (Coe)
147-lb.	DePrenger (Cornell)	Uzodinma (Grinnell)	Hardesty (Carleton)	Beckman (St. Olaf)
157-lb.	Miller (Cornell)	Wenaas (St. Olaf)	Reuben (Grinnell)	Rosenberg (Coe)
167-lb.	Sonneman (Cornell)	Mayfield (Grinnell)	Hanson (Lawrence)	Pressendo (Carleton)
177-lb.	Lindell (Cornell)	Olson (St. Olaf)	Gerks (Coe)	Ziebell (Lawrence)
Hvywt.	Hanson (Ripon)	Hamilton (Coe)	Oetting (Lawrence)	Quam (St. Olaf)

TEAM SCORING

Cornell 45, Grinnell 19, Coe 16, St. Olaf 14, Carleton 12, Ripon 12, Lawrence 6, Knox 2.

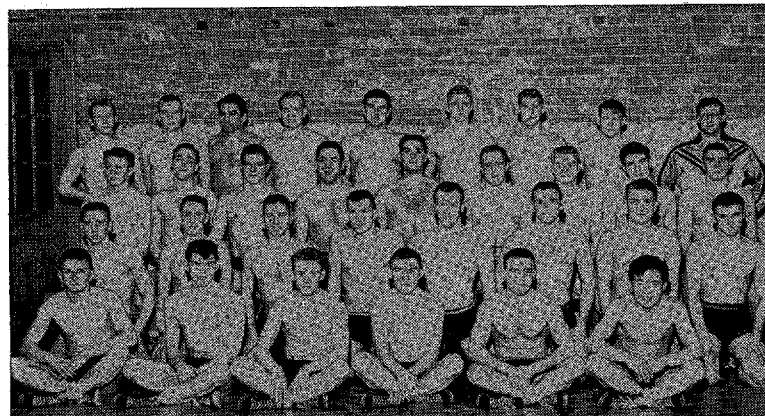

FOURTH IN NATION—IOWA TEACHERS: Left to right, front row—Gutknecht, Sesker, Knight, Corrigan, McCarron, Sasaki; second row—Cook, Bress, Drake, Laughlin, Sterner, Livingston, Dornfeld, Koch; third row—Whitmore, Morris, Gatto, Papousek, Burreight, Oles, Ewoldt, Ceilley, Harmon; fourth row—Butterfield, Stephens, Lofredo, Harford, Thompson, Ludwig, Jones, Lukenbach, Koll (coach).



IOWA CONFERENCE CHAMPS—LUTHER COLLEGE: Left to right, front row—Krueger, Aves, O. Erslund, Ketelsen, Jungck, Anderson; back row—Knudson (manager), Smoczynski, G. Erslund, Lunde, Hanson, Berg, Schutz (coach). Luthier wrestlers took all but two conference individual titles, which went to Dubuque and Wartburg.



ST. JOHN'S-MINNESOTA CONFERENCE POWERS: Left to right, front row—DeVaughn, McKeown (coach), Miller, Grant, Duffy (manager); back row—Kaiser, Tachney, Kemper, Forster.

IIAC Tournament

By **WOODY HASEMANN**, Northern Illinois STC

Pin points were the difference as Illinois State Normal University snatched the Interstate Intercollegiate Athletic Conference championship by a one-point margin, March 7 at DeKalb, Illinois. The results were a reversal of the 1952 meet, when favored Illinois Normal lost its crown to Northern Illinois, the 1953 host.

Normal and Northern each copped three individual titles, with Southern Illinois and Western Illinois each getting one. Northern had one more second place than the winners, but Normal's eight falls were more than the Huskies could match.

INDIVIDUAL CHAMPIONS AND PLACE WINNERS

Class	Champion	Second	Third
123-lb.	Whelan (Southern Ill.)	Jarf (Northern Ill.)	Cheney (Ill. Normal)
130-lb.	Reimer (Northern Ill.)	Riggan (Southern Ill.)	Krider (Ill. Normal)
137-lb.	Meridith (Northern Ill.)	Bruno (Ill. Normal)	Stoudt (Southern Ill.)
147-lb.	Francour (Ill. Normal)	Fedora (Southern Ill.)	Hopkins (Northern Ill.)
157-lb.	Egofske (Ill. Normal)	Ruskin (Northern Ill.)	Zdenek (Southern Ill.)
167-lb.	Lauss (Ill. Normal)	Sims (Northern Ill.)	Veremis (Southern Ill.)
177-lb.	Mers (Northern Ill.)	Hoffman (Ill. Normal)	Hargis (Southern Ill.)
Hvywt.	DeTaeve (Western Ill.)	Werner (Southern Ill.)	Krupake (Northern Ill.)

TEAM SCORING

Illinois Normal 31, Northern Illinois 30, Southern Illinois 20, Western Illinois 7, Eastern Illinois 0.

Big Seven Conference Tournament

By **BOB HENTZEN**, Sports Publicity, Oklahoma

The University of Oklahoma for the fourth consecutive year completely dominated the Big Seven Conference wrestling tournament held March 13 and 14 on the Sooners' home mat in Norman.

Coach Port Robertson's grapplers earned five individual championships, two seconds and a third place to score 45 points, 19 more than Coach Hugo Otopalik's Iowa State matmen who garnered runner-up honors in the five team field with 26 points. Kansas State was third with 17, while Nebraska and Colorado had 13 each.

Frank Marks, 167-pound Oklahoman, won his third consecutive title. Don Reece, 123, Harold Reece, 130 and Bryan Rayburn, 147, took their second individual crowns for the Sooners. Bob Wirts, Iowa State's 177-pounder, also won his second title, while Ronald Scott of Oklahoma at 137, Les Kramer of Kansas State at 157 and Ed Husmann of Nebraska at heavyweight captured their first league championships.

INDIVIDUAL CHAMPIONS AND PLACE WINNERS

Class	Champion	Second	Third	Fourth
123-lb.	D. Reece (Oklahoma)	Mancuso (Kansas St.)	Torgerson (Colorado)	Bean (Nebraska)
130-lb.	H. Reece (Oklahoma)	Long (Colorado)	Oscarson (Iowa St.)	Spring (Kansas St.)
137-lb.	Scott (Oklahoma)	Ruzic (Iowa St.)	Artemis (Colorado)	Webster (Kansas St.)
147-lb.	Rayburn (Oklahoma)	Leitel (Nebraska)	Ellingson (Iowa St.)	Spicher (Kansas St.)
157-lb.	Kramer (Kansas St.)	Eagleton (Oklahoma)	Derby (Colorado)	Hayungs (Iowa St.)
167-lb.	Marks (Oklahoma)	Larsen (Iowa St.)	Smith (Colorado)	Pacha (Kansas St.)
177-lb.	Wirts (Iowa St.)	Kelley (Oklahoma)	Weaver (Kansas St.)	Schalk (Colorado)
Hvywt.	Husmann (Nebraska)	Waldon (Iowa St.)	Hearon (Oklahoma)	Marciniak (Kansas St.)

TEAM SCORING

Oklahoma 45, Iowa State 26, Kansas State 17, Colorado 13 and Nebraska 13.



BIG SEVEN KINGPINS—OKLAHOMA: Left to right, first row—Blubaugh, J. Corr, Young, H. Reece, D. Reece, Todd, Evans, Borders (asst. coach); second row—Zink, E. Corr, Bolding, Pierce, Eagleton, Scott, Rayburn, Skelenda, Stokes; third row—Hearon, Kelley, Willis, White, Bross, Cunningham, Cross (president), Marks.



SKYLINE CIRCUIT PLACE WINNERS: Left to right, front row—Hockley (Wyo.), Woodward (Colo. A&M), Datteri (Colo. A&M), Ballinger (Wyo.), Sniff (Colo. A&M), Broughton (Colo. A&M), McCullough (Wyo.), Grant (Utah); second row—Miller (Colo. A&M), Herbertson (Wyo.), Jordan (BYU), Lockwood (Colo. A&M), B. Hockley (Wyo.), Martin (Wyo.), Dracayer (Utah), Binkley (Colo. A&M); third row—Wilson (BYU), Steck (BYU), Robinson (Wyo.), Motto (Utah St.), Grunig (Utah St.), Rydalch (Utah), Pettis (Colo. A&M), Thomas (Wyo.); back row—Billings (Utah), Bishop (Utah), Whitty (Utah St.), Rollins (BYU), Ashton (BYU), Matthews (Utah St.), Hale (BYU), Robinson (BYU). Colorado A&M regained team title from Wyoming, which had won conference tourney three years in a row.

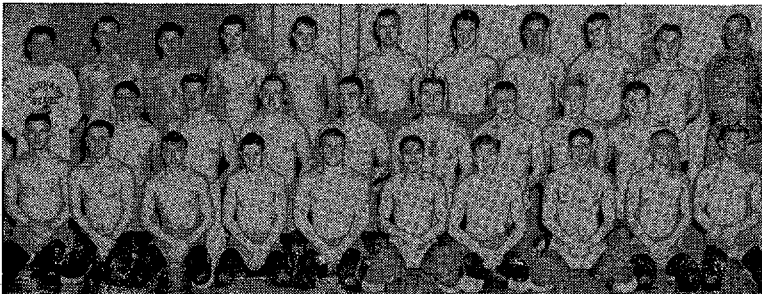

COLORADO STATE'S 17TH TITLE SQUAD: Left to right, front row—Bishop, Reynolds, Brown, Roberts, Williams, Sandoval, Shupe, Himes, Sheperd, Nonnie; second row—Frakes, Gardner, Collins, Kelly, Cott, Beall, Brush, Blackwell; back row—Govoni (asst. coach), Overturf, Bronstein, Greenhalge, Gasewood, Daugherty, Woods, Laugesen, Cason, Doubenmeier (coach).

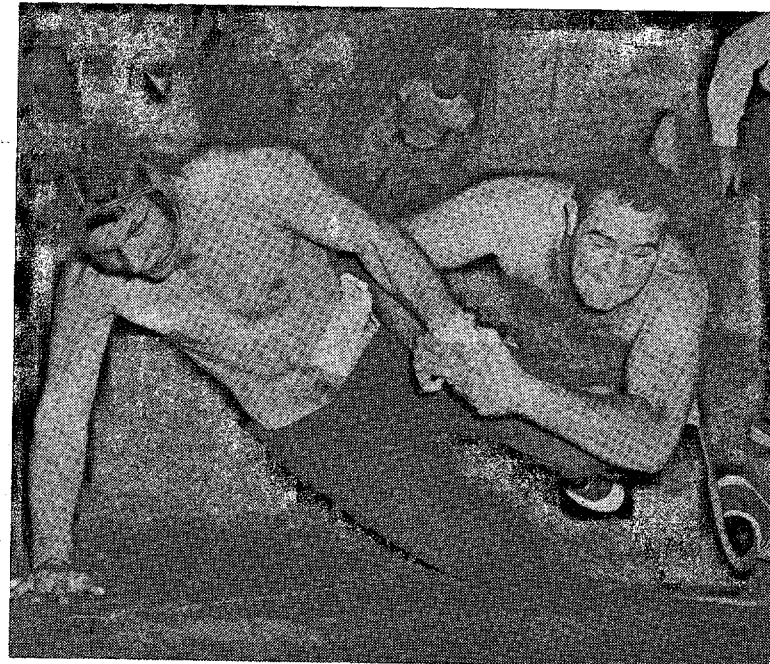

NOW THERE WERE THESE TWO BEARS—Jack Ellena (right) of UCLA (Bruins) is about to pin Al Mostin of California (Bears) in Pacific Coast Conference match. Ellena won Coast's heavyweight crown, as well as this dual meet bout.

Rocky Mountain Conference Tournament

By JOHN HANCOCK, Coach, Colorado State College

Colorado State won its 17th straight Rocky Mountain Conference wrestling title when the Bears captured six individual titles and tallied 42 points in the meet held at Bozeman, Montana.

Colorado Mines was runner-up with 26 points, followed by Montana State 19, Colorado Western State 18 and Idaho State 2.

Winning titles for the Bears were Larry Nonnie, 123 pounds; Brown Brown, 130; George Sheperd, 137; Ben Bronstein, 147; Hoy Frakes, 177 and Ivan Kelly, heavyweight.

INDIVIDUAL CHAMPIONS

Class	Champion	Class	Champion
123-lb.	Nonnie (Colo. State)	157-lb.	Cramer (Montana St.)
130-lb.	Brown (Colo. State)	167-lb.	Allen (Montana St.)
137-lb.	Sheperd (Colo. State)	177-lb.	Frakes (Colo. State)
147-lb.	Bronstein (Colo. State)	Hvywt.	Kelly (Colo. State)

Pacific Coast Intercollegiate Tournament

By F. SHELDON HARDEN, Coach, California State Polytechnic College

The 1953 PCI championship tournament, held at Calif. Poly, San Luis Obispo, Calif., developed into a thrill-packed contest up to the remaining final matches with Washington State edging Oregon State in the final matches. When the tournament came to a close, Washington State was the winner of the fourth annual Pacific Coast tourney with 52 points and Oregon State the runner-up with 34 points. Nine schools participated.

Delance Duncan of Washington State was a repeat champion in winning the 137-pound class. He won the 147-pound division last year.

The competitive spirit and competition were excellent. Gary McLain of Oregon State was named the outstanding wrestler of the tourney.

The only undefeated team on the Pacific Coast this season was Washington State. California schools competed in the Far Western Open Tournament and held their own in competition with several strong service teams.

INDIVIDUAL CHAMPIONS AND PLACE WINNERS

Class	Champion	Second	Third	Fourth
115-lb.	McClain (Ore. State)	Holt (Wash. State)	Kurtz (California)	Toyato (San Jose)
123-lb.	Gibson (Wash. State)	Perry (California)	Ross (San Jose)



PACIFIC COAST'S INDIVIDUAL CHAMPS: Left to right, front row—McLain (Oregon St.), Gibson (Wash. St.), Robinson (San Diego St.), Duncan (Wash. St.), Nelson (Wash. St.); back row—Giester (Oregon St.), McGhee (Wash. St.), Francis (San Jose St.), Williams (Oregon St.), Ellena (UCLA).

130-lb.	Robinson (San Diego)	Peppel (Wash. State)	Sanders (California)	Ornellus (Santa Clara)
137-lb.	Duncan (Wash. State)	Sease (Ore. State)	Farnham (Calif. Poly)	Russell (Stanford)
147-lb.	Nelson (Wash. State)	Tubbs (Ore. State)	Meyers (San Diego)	Bordelon (Santa Clara)
157-lb.	Giester (Ore. State)	Kettering (Calif. Poly)	Needham (Wash. State)	Leslie (San Jose)
167-lb.	McGhee (Wash. State)	Becker (Ore. State)	Leamer (California)	Thomas (UCLA)
177-lb.	Francis (San Jose)	Hitchcock (Wash. State)	Harsey (Ore. State)	Studer (Calif. Poly)
191-lb.	Williams (Ore. State)	Crabbe (Wash. State)	Lauter (UCLA)	Mostin (California)
Hvywt.	Ellena (UCLA)	Borebuck (San Jose)	Pixley (Wash. State)	Guyer (Ore. State)

TEAM SCORING

Washington State 52, Oregon State 34, San Jose State 17, UCLA 12, California 10, California Poly 9, San Diego State 9, Santa Clara 2, Stanford 1.

Canadian Intercollegiate Wrestling Tournament

By MICHAEL S. YUHASZ, Coach, McGill University

McGill University acted as hosts for the Canadian Intercollegiate Wrestling Tournament held in Montreal on February 27 and 28.

Western Ontario, the defending champion, piled up 40 points to retain the team championship. Toronto, Ontario Agricultural and McGill followed closely with 31, 28 and 26 points, respectively.

Two individual champions retained their titles: Gray of Ontario Agricultural and Hubling of Western Ontario. Lillie of McGill, the 123-pound titlist, was named the outstanding wrestler of the tournament.

Of the 46 matches in the tournament 20 ended in falls, indicating the emphasis placed by Canadian coaches on the fall.

The 1954 championships will be held at Queen's University in Kingston, Ontario on February 26 and 27.

INDIVIDUAL CHAMPIONS AND PLACE WINNERS

Class	Champion	Second	Third	Fourth
123-lb.	Lillie (McGill)	Wood (Toronto)	Ferguson (Ontario Agr.)	Clutchev (Western Ont.)
130-lb.	Weeden (Ontario Agr.)	Fujimagari (McGill)	Brown (Western Ont.)	Pitman (Toronto)
137-lb.	Leyshon (Western)	Hatashita (Toronto)	Waddell (McGill)	Hammatt (Queens)
147-lb.	Preston (Western Ont.)	Kopera (Toronto)	Poirier (Ontario Agr.)	Woods (McGill)
157-lb.	Gray (Ontario Agr.)	Bush (Toronto)	Malo (Western Ont.)	Gerrett (Queens)
167-lb.	Thompson (Western Ont.)	Siemonsen (Queens)	Menard (McGill)	Waugh (Toronto)
177-lb.	Biewald (McGill)	Brightwell (Ontario Agr.)	Wooden (Western Ont.)	Bell (Toronto)
191-lb.	Hamilton (Toronto)	Berthelot (Queens)	Dunbar (Western Ont.)	Baikie (McGill)
Hvywt.	Hubling (Western Ont.)	Burt (Ontario Agr.)	Fancy (Queens)	Ford (Toronto)

TEAM SCORING

Western Ontario 40, Toronto 31, Ontario Agricultural 28, McGill 26, Queens 12.

1953 Dual Meet Records

School	Coach	Record	School	Coach	Record
Akron, U. of	Andy Maluke	4-4-0	Mankato St. Tchr.	Rummy Macias	4-4-0
Alfred University	A. Yunevich	2-3-0	Marquette U.	L. Lederman	6-7-0
Amherst College	Ben McCabe	6-1-0	Maryland, U. of	Wm. Kruse	6-1-0
Arkansas St. Col.	H. J. Nichols	8-1-0	Mass. Inst. of Tech.	S. Buckstaff	3-4-0
Army	L. Appleton	7-3-0	McGill University	M. S. Yuhasa	3-3-0
Auburn	Swede Umbach	10-0-0	Miami U. (O.)	E. Colville	4-2-0
Augustana (Ill.)	Vin Lundeen	7-4-0	Michigan St. Col.	F. Collins	7-2-0
Baldwin-Wallace	John Sumner	7-1-0	Michigan, U. of	Cliff Keen	8-1-0
Baltimore, U. of	Phil Labrey	4-0-1	Middle Tenn. St.	Joe Hayes	6-3-1
Boston University	Chin Kerr	0-5-0	Millersville St.	H. G. Hurst	5-2-0
Bowling Green St.	B. H. Bellard	0-9-0	Minnesota, U. of	W. Johnson	6-2-0
Brigham Young U.	Beed Nilson	2-2-1	Montana St. Col.	Max Kimberly	1-2-1
Brooklyn Poly	Edw. Collins	1-8-0	Muhlenberg College	F. H. Wellows	1-6-0
Brown University	E. Anderson	3-4-1	Navy	Ray Swartz	5-3-0
Bucknell Univ.	Herb Maack	4-4-0	Navy Pier	E. D. Ryan	3-1-0
Buñalo, U. of	George King	2-7-0	New York U. of	Al Partin	3-2-0
California Poly	Shel Harden	3-4-1	N. Carolina, U. of	C. Henriquez	7-2-0
California, U. of	Henry Stone	2-4-1	N. Carolina, U. of	Sam Barnes	3-7-0
Carleton College	E. Hennrichson	4-6-0	Northern Ill. St.	Bob Kahler	3-2-2
Case Inst. of Tech.	H. Sheer	9-4-0	Northwestern U.	Jack Riley	4-3-0
Champlain College	H. Stein'son	4-5-0	Ohio State U.	C. Fredericks	0-6-0
Cisadel, The	Wm. Bostwick	3-1-0	Ohio University	F. Schiechler	3-4-0
City Col. of N.Y.	Joe Sapora	3-4-0	Oklahoma A&M Col.	Art Griffith	2-3-0
Clarkson Tech	R. Bloodgood	4-0-0	Oklahoma, U. of	P. Robertson	7-0-0
Coast Guard Acad.	Wm. Hammer	5-3-0	Oklahoma, U. of	Jim Dixon	4-4-0
Coe College	Chas. Brooks	5-4-0	Oregon State Col.	C. Speidel	9-0-0
Colorado A&M Col.	J. F. Wagner	8-2-0	Penn. State Col.	C. Bidenour	0-10-1
Colorado Mines	Keith Bowen	6-8-0	Pennsylvania, U. of	Rex Peery	10-1-0
Colorado State	John Hancock	6-7-0	Pittsburgh, U. of	H. Westcott	3-5-0
Colorado, U. of	Ray Jenkins	6-4-0	Portland St. Col.	James Beed	6-1-0
Columbia U.	Chas. Bryant	4-4-1	Purdue University	Claude Beek	1-8-2
Cornell Col. (Ia.)	Eric Miller	7-4-0	Ripon College	C. Stevens	4-4-0
Cornell University	David Miller	5-3-0	Rochester Tech	E. W. Fuller	7-3-0
Corland St. Tchr.	Chas. Parker	0-9-0	Rutgers University	Dick Voliva	9-2-0
Delaware, U. of	A. Burnham	8-2-0	St. John's (Minn.)	Jim Mackown	4-4-0
Denver, U. of	Lou Young	0-7-0	St. Olaf College	Don Olson	8-6-0
Drexel Tech	R. DiBattista	2-4-0	San Diego St. Col.	H. H. Mumby	8-1-0
Dubuque, U. of	T. Schorone	3-2-0	San Jose St. Col.	Hal Holmes	2-4-0
Duke University	C. Falcone	5-2-0	South Dakota State	J. Wilkinson	3-7-1
East Stroudsburg	G. Ock'son	1-5-0	Southern Ill. U.	Ray Sparks	7-2-1
Edinboro St. Tchr.	John Miller	0-7-0	Stanford U.	Don Williams	6-5-0
Emory University	I. Mancuso	5-2-0	Stevens Point St.	John Roberts	3-3-0
Findlay College	W. R. Phillips	7-2-0	Swarthmore College	Homer Davies	3-5-0
Gallaudet College	Tom Clayton	7-2-2	Syracuse U.	J. McDaniel	4-3-0
Gettysburg College	J. Shainline	7-1-0	Temple University	C. Demetries	0-9-0
Grinnell College	Bob Peterson	4-5-0	Toledo, U. of	Joe Scalzo	8-2-0
Harvard University	Bob Pickett	5-3-2	Toronto, U. of	K. A. Wipper	3-2-0
Haverford College	G. C. Harter	4-4-0	Tufts College	S. Ruggieri	1-6-0
Hofstra College	Walter Stone	4-7-0	U.C.L.A.	Briggs Hunt	3-2-0
Illinois St. Normal	Eugene Hill	4-7-0	Ursinus College	K. Wieneke	3-4-0
Illinois Tech	R. Patterson	8-5-2	Utah, U. of	K. Schleckman	3-1-0
Illinois, U. of	Lew Shaffer	4-5-0	Virginia Mil. Inst.	O. W. Gupton	3-6-0
Indiana St. (Pa.)	C. McDandel	3-5-1	Virginia Tech	Frank Teske	6-1-1
Iowa State College	H. Otopolik	9-1-0	Virginia, U. of	Frank Finger	5-4-0
Iowa St. Tchr. Col.	Bill Koll	4-2-1	Warburg College	N. Johansen	6-1-1
Iowa, U. of	D. McCuskey	3-4-1	Washington & Lee	Bill Tomaras	6-0-0
Ithaca College	H. Broadwell	8-1-0	Washington State	Ray Murdock	6-1-1
Kansas State Col.	Leon Bernard	3-8-0	Waynesburg College	Will Trezise	7-2-0
Kent State U.	Jos. Begala	6-3-0	West Chester State	H. C. Ave	2-5-0
Kings Point	Glen Stralka	3-4-0	Western Ill. State	E. Zeligler	5-2-0
Knox College	Arthur Fish	1-3-1	Western Ont. U. of	R. Grueninger	0-8-0
Lafayette College	P. Eisenhauer	10-1-0	Western Reserve U.	S. Harrick	8-2-0
Lawrence College	B. Heselton	7-1-0	West Virginia U.	Geo. Olson	5-4-0
Lehigh University	G. Leeman	8-2-0	Wheaton College	Lou Blockus	1-6-0
Lincoln U. (Pa.)	Bob Gardner	2-4-0	Wilkes College	J. E. Bullock	3-5-0
Lock Haven State	Hubert Jack	8-3-1	Williams College	J. E. Martin	1-8-0
Long Island A&T	R. MacArthur	5-2-0	Wisconsin, U. of	Geo. Lederman	1-12-0
Loyola College	Emil Beitz	3-3-0	Wisconsin Ext.	Walter Smith	3-2-1
Luther College	Howie Schutz	3-4-1	Wright Junior Col.	Glen Mangus	6-3-0
			Wyoming, U. of	J. O'Donnell	5-4-0
			Yale University		

SCHOLASTIC REVIEWS

California

By FRANK M. CROSBY, Coach, San Diego High School

The 28th consecutive season of wrestling for high schools of Southern California was brought to a successful climax on March 7, 1953. San Diego High School was able to retain the team championship for the fourth straight year, even though a majority of the individual championships were won by boys from the Los Angeles area.

The year was very satisfactory in spite of the fact that several schools dropped the sport. The wrestling schools were divided into two districts, one comprising San Diego County and the other one, all the rest of Southern California. East district was authorized to qualify four contestants in each weight for the finals.

INDIVIDUAL CHAMPIONS AND PLACE WINNERS

Class	Champion	Second	Third	Fourth
95-lb.	Hunsocker (Redlands)	Kirshbaum (Hawthorne)	Duncan (Vocational)	Corcoran (Whittier)
103-lb.	B. Hernandez (Whittier)	E. Hernandez (Redondo)	Sisco (Leuzinger)	Luxa (Escondido)
112-lb.	Bodenhamer (Kearny)	Barbo (Redlands)	Escobar (Leuzinger)	Routh (San Diego)
120-lb.	Rowe (Whittier)	Saunar (San Diego)	Gardner (Redondo)	Shoen (Kearny)
127-lb.	Cadava (San Diego)	Thomason (Morningside)	Nees (Redondo)	Bridges (Kearny)
133-lb.	Loos (Clino)	Hall (San Diego)	Branason (Redondo)	Osborn (Vocational)
138-lb.	Harmon (Vocational)	Close (San Diego)	Dufresne (Kearny)	Spark (Chino)
145-lb.	Billington (Inglewood)	Johnson (San Diego)	Brown (Redondo)	Wirner (Vocational)
154-lb.	Carlson (Inglewood)	Hoppe (Redondo)	Minafee (San Diego)	Penick (Vocational)
165-lb.	Woodson (San Diego)	King (Redondo)	Malias (Inglewood)	Row (La Jolla)
175-lb.	Hutchemson (Redondo)	Elwell (Coronado)	Quesada (Redlands)	Conger (Vocational)
190-lb.	Patten (San Diego)	Henderson (Army-Navy)	Gibson (Inglewood)	Parks (Redlands)
Hvywt.	Clark (Inglewood)	Gilliland (Kearny)	Mesa (Whittier)	Cascioppa (Escondido)

TEAM SCORING

San Diego 42, Redondo 31, Inglewood 28, Whittier 17, Redlands 15, Kearny 14, Vocational 12, Chino 8, Hawthorne 8, Escondido 7, Army-Navy 6, Morningside 5, Coronado 4, Leuzinger 4, La Jolla 1, Beverly Hills 0, Rancho Del Campo 0, Mira Costa 0.

Colorado

The 18th Annual State Wrestling Tournament was held in the City Auditorium, Denver, February 20-21. Forty-six high schools qualified men to participate in this event.

For the first time the school in each classification, AA, A, BC, making the highest number of points in that classification was awarded a trophy. The team champions were: Colorado Springs High School (AA), Arvada High School (A) and Palisade (BC).

TEAM SCORING

Colorado Springs 23, Fort Collins 16, Arvada 15, Greeley 14, Rocky Ford 14, North (Denver) 13, Westminster 13, Centennial 11, West (Denver) 11, Montross 11, Longmont 7, South (Denver) 7, Fort Morgan 7, Palisade 7, Central 6, East (Denver) 6, Grand Junction 5, Englewood 4, Hotchkiss 4, Golden 3, La Junta 3, Wheat Ridge 3, Monte Vista 3, Delta 2, Las Animas 2, Hayden 1.

Illinois

By **JUG BECK**, Assistant Wrestling Coach, U. of Illinois

Amateur wrestling continues to gain popularity in Illinois High Schools with more and more schools adding wrestling to their athletic programs. This year 46 teams sent representatives to the state finals via the eight sectional tournaments, an all-time high. Of these, 31 scored points in the finals held at the University of Illinois where 192 wrestlers competed in 12 weight classes.

As usual, competition was keen and the caliber of wrestling was even higher than usual. Over 5,500 fans attended the four sessions held in Huff Gymnasium.

New Trier of Winnetka showed unusual team balance in scoring points in six weight classes. Coach Al Hurley's squad scored 24 points in gaining its second state team title in three years. Place winners included champions William Muther at 138 pounds and John O'Neil at 145; runner-up Terry Stanton at 154 and third place winner Jack Snell at 120. New Trier also scored more falls than any other team picking up six points via that route.

INDIVIDUAL CHAMPIONS AND RUNNER-UPS

Class	Champion	Runner-up
95-lb.	Goodnick (Belleville)	Bergquist (Reavis)
103-lb.	Whitlatch (Urbana)	Moore (Danville)
112-lb.	Duck (Moline)	Robles (Tilden)
120-lb.	Meeks (Champaign)	Cole (Evanston)
127-lb.	Avellano (Thornton)	Ettswold (Maine)
133-lb.	Crisler (Thornton)	Hoffman (Moline)
138-lb.	Muther (New Trier)	Valentine (Urbana)
145-lb.	O'Neil (New Trier)	Matteson (Champaign)
154-lb.	Fugett (Tilden)	Stanton (New Trier)
165-lb.	Kelly (Proviso)	Strasser (Calumet)
175-lb.	Monroe (Tilden)	Demos (Evanston)
Hvywt.	Price (Joliet)	Sheets (Danville)

TEAM SCORING

New Trier (Winnetka) 24, Thornton (Harvey) 19, Tilden (Chicago) 18, Champaign 15, Evanston 15, Moline 12, Danville 10, Urbana 10, Waukegan 9, Joliet 8, Calumet (Chicago) 7, Wood River 6, Sterling 6, Proviso (Maywood) 6, Belleville 6, Reavis (Oak Lawn) 5, Rock Island 5, Maine (Des Plaines) 4, Pekin 4, Granite City 3, Lyons (La Grange) 3, Riverside-Brookfield 2, Hirsch (Chicago) 2, Blue Island 1, Hinsdale 1, Grange 1, Franklin Park 1, Morton (Chicago) 1, Paxton 1, Oak Lawn, Thornton Fractional (Calumet City) 1, Bloom (Chicago) 1.

Iowa

By **FINN B. ERIKSEN**

The 32nd Iowa Interscholastic wrestling tournament was held at Iowa State Teachers College Gymnasium in Cedar Falls on February 27-28.

The East Waterloo grapplers, coached by Davis Natvig, climaxed a perfect season by winning the team title. This is the first time the championship has been won by East Waterloo, although the team had been in the runner-up spot on several previous occasions. Teams from Cresco, Newton and Iowa Falls were in the running for championship honors throughout the tourney.

Three 1952 champions successfully defended their titles: Eddie Kline, Mason City; Ronnie Gray, Eagle Grove and Donald Hall of Cresco.

This year's state tourney was a straight elimination arrangement with the loser in the championship final automatically taking second place. The two semi-final losers wrestled it out for third and fourth places. The new tournament set-up proved very successful.

TEAM SCORING

East Waterloo 23, Cresco 18, Newton 17, Iowa Falls 13, West Waterloo 12, Roosevelt (Cedar Rapids) 11, Eagle Grove 10, Mason City 9, Cedar Falls 8, Clarion 7, Teachers (Cedar Falls) 6, Davenport 6, Osage 6, Charles City 5, New Hampton 5, Tama 5, Corpus Christi (Fort Dodge) 5, Clinton 4, Abraham Lincoln (Council Bluffs) 4, Britt 2, Franklin (Cedar Rapids) 2, McKinley (Cedar Rapids) 1, East Des Moines 1, Hartley 1, Maquoketa 1, Waverly 1.

Kansas

By **BARNEY BORING**

St. Francis defended its state championship title in a close, action-packed tournament conducted at Salina, February 27 and 28, before a crowd of approximately 1,500.

The scores among the teams having representatives were as follows: St. Francis 33, Wichita East 31, Salina 29, Colby 22, Goodland 21, Atwood 11, El Dorado 11, Winfield 8, Wichita North 8, Oberlin 4, Norton 1, Topeka 1, Almena 0, Douglas 0, Oakley 0 and Hoxie 0.



KANSAS HIGH SCHOOL POINT GETTERS: Left to right, front row (champs)—Lara (El Dorado), House, Frietag (both Goodland), Goldsworth (Colby), Skelton (Goodland), Neville, Cecil (both St. Francis), Ruffin (Wichita North), Haller (Colby), Crick (Wichita East), Harding (Winfield), Hull (Wichita East); second row (runners-up)—Gawith, Webb (both Salina), Urey (El Dorado), Braumard (Oberlin), Prochop (Atwood), Nichols (Salina), Kimple, Rosendale (both Wichita East), Dar Moberly (St. Francis), Strickland (Salina), Wickwar (St. Francis), Sweazy (Colby); third row (3rd places)—Foster (Colby), Rummel (Atwood), Schroeder (Colby), Isernhagen (St. Francis), Morrison (Salina), Morgan (Atwood), Dearing (Colby), Burr (St. Francis), Schneider (Salina), Ross (St. Francis), Gibson (Wichita East), Jenney (Salina); back row (4th places)—Henrett (Norton), Pierson, McGinnis (both Wichita East), Torres (Salina), Henry (Colby), Russell (Wichita East), Warner (Topeka), King (Winfield), Heaston (Wichita East), Kirtman (El Dorado), Kasiner (Salina), Don Moberly (St. Francis).

Wichita East won the Eastern Regional, with Salina second. St. Francis won the Western Regional, followed by Colby.

Salina conducted a superbly-organized tournament, officiated by Leon Reynard and Stan Fansher. The coaches' meeting prior to the event was highly successful and definite measures were taken to promote wrestling in Kansas.

Maryland

By MURRAY WIEMAN, *The Baltimore Evening Sun*

Gilman School won the 33rd annual Maryland Scholastic Association Wrestling tournament, edging out McDonogh School, 32½ to 31½, as a result of Gilman's Pete Alexander's pinning his opponent in the 175-pound division.

The extra point provided by the fall meant the margin of victory. Had Alexander simply decided his foe, the tourney would have been tied. Gilman gained a leg on the Lehigh Cup, team trophy given annually.

The 1953 title was the 15th for Coach Eddie Russell, who has directed Gilman teams for 33 years. This was his first championship since 1940, however.

The dual system of champions prevails in the M.S.A., so McDonogh is recognized as dual-meet titlist since it went through the season undefeated in nine matches.

INDIVIDUAL CHAMPIONS AND RUNNER-UPS

Class	Champion	Runner-up
112-lb.	Williamson (McDonogh)	Lipka (Patterson)
120-lb.	Boxwell (Southern)	Neary (City)
127-lb.	Eck (Gilman)	Clarke (Mt. St. Joseph)
133-lb.	Turner (Gilman)	Naylor (McDonogh)
138-lb.	Hornor (McDonogh)	Ward (Mt. St. Joseph)
145-lb.	Lox (Polytechnic)	Mundorf (Mt. St. Joseph)
154-lb.	Nichols (McDonogh)	Burdette (City)
165-lb.	Carey (Gilman)	Wisniewski (Patterson)
175-lb.	Alexander (Gilman)	Bankert (Mt. St. Joseph)
Hvywt.	Petrilli (Mt. St. Joseph)	Hunt (Polytechnic)

TEAM SCORING

Gilman 32½, McDonogh 31½, Mt. St. Joseph 25½, Polytechnic 17½, Southern 11½, Patterson 11½, City 11½, Severn 2½.

Michigan

By FENDLEY COLLINS, *Wrestling Coach, Michigan State College*

High school wrestling is comparatively young in the State of Michigan. However, this year at the Sixth Annual Championships, 150 wrestlers from 18 schools participated.

A nice, healthy rivalry has developed between two Lansing schools—Sexton, coached by Iggy Konrad, and Eastern, coached by Don Johnson. After a two-year reign by Eastern, the Sexton matmen dominated the 1953 tournament by winning five titles and five runner-up positions. Ann Arbor, which is a continual threat, finished third.

INDIVIDUAL CHAMPIONS AND PLACE WINNERS

Class	Champion	Second	Third	Fourth
95-lb.	Bates (Lansing East.)	Payne (Lansing Sex.)	Jones (Ypsilanti)	Vivian (Hazel Park)
103-lb.	Dietrich (East Lansing)	Swix (Lansing Sex.)	Wilson (Lansing East.)	Odegard (Ypsilanti)

112-lb.	Stroud (Lansing Sex.)	White (MSB)	Ritter (Lansing East.)	Byce (Davison)
120-lb.	Cook (Ann Arbor)	Richardson (East Lansing)	Washburn (Jackson)	Towler (Ypsilanti)
127-lb.	Spitt (Ann Arbor)	Hough (Lansing Sex.)	Thompson (Jackson)	Boyd (Ypsilanti)
133-lb.	Schworer (Lansing Sex.)	Elliott (Ypsilanti)	Wood (Jackson)	Fuller (Lansing East)
138-lb.	Granger (Lansing Sex.)	Allen (Lansing East.)	Sherman (Ann Arbor)	Harvey (Battle Creek)
145-lb.	Tavener (Lansing East.)	Jones (Lansing Sex.)	Evans (Battle Creek)	Clark (Davison)
154-lb.	Cary (Lansing East.)	Steadman (Lansing Sex.)	Lamphear (East Lansing)	Sanders (Jackson)
165-lb.	Pullen (Ann Arbor)	Thompson (Lansing East.)	Sanson (Hazel Park)	Keagle (Jackson)
175-lb.	Maidlow (Lansing Sex.)	Fladseth (Lansing East.)	Foster (Niles)	Cleaver (Hazel Park)
Hvywt.	Reglin (Lansing Sex.)	Zervas (Hazel Park)	Williams (Ann Arbor)	Yore (Battle Creek)

TEAM SCORING

Lansing Sexton 67, Lansing Eastern 46, Ann Arbor 29, Jackson 16, Ypsilanti 15, East Lansing 14, Hazel Park 12, Davison 8, Battle Creek 8, Michigan School for the Blind 6, Niles 4, Lansing Everett 2, Sturgis 1, Berkley 1.

Mid-South Wrestling Tournament

Baylor School of Chattanooga, Tennessee, successfully defended its Mid-South wrestling tournament, held at Baylor on February 20 and 21.

Coach Luther Worsham's champions took four individual titles, five seconds and a third place to rack up 55 points. McCallie for second with 48. Tom Drake and Mack Davis handled the officiating for the tournament, participated in by seven schools.

INDIVIDUAL CHAMPIONS AND PLACE WINNERS

Class	Champion	Second	Third	Fourth
100-lb.	Lott (CMA)	Sherrill (McCallie)	Krauth (Baylor)	Clough (SMA)
108-lb.	Munroe (SMA)	Sams (Baylor)	Williams (McCallie)	Snips (CMA)
115-lb.	McCrory (Baylor)	Stone (CMA)	Christian (McCallie)	Cleaves (CMA)
123-lb.	Clements (McCallie)	Roddy (Baylor)	Cubillan (GMA)	Evins (CHMA)
130-lb.	Goodloe (Baylor)	McDonald (McCallie)	Pinney (SMA)	Davis (GMA)
137-lb.	Sheppard (McCallie)	Scruggs (Baylor)	Haynes (CMA)	Burn (GMA)
147-lb.	Buckles (CHMA)	Grimes (Baylor)	Gibson (McCallie)	Patton (CMA)
157-lb.	Lewis (CMA)	Johnson (Baylor)	Adams (McCallie)	Warner (SMA)
167-lb.	Turner (McCallie)	Floyd (GMA)	Ellis (CHMA)	Laxson (SMA)
177-lb.	Cox (Baylor)	Smith (SMA)	Hammon (McCallie)	Lile (CMA)
191-lb.	Stone (CHMA)	Gould (McCallie)	Gidden (CMA)	Rhodes (Baylor)

Hvywt. Healey (Baylor) Armstrong (CEMA) Pelham (McCallie) Floyd (GMA)

TEAM SCORING

Baylor 55, McCallie 48, Castle Heights 24, Columbia Military 23, Sewanee Military 20, Georgia Military 11, Notre Dame 0.

Missouri

By MORRIS BLITZ, Coach, Normandy High School, St. Louis

Approximately 130 wrestlers, involving 15 schools, participated in the 15th Annual State Tournament. Ritenour High School of Overland won its fifth straight championship with Webster Groves and Normandy closely contesting for second place.

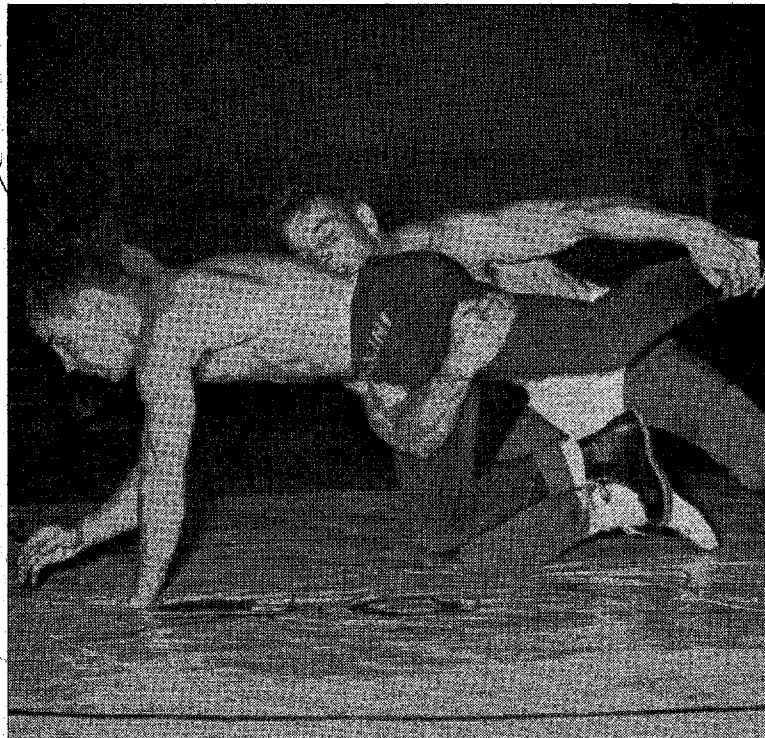

MORE THAN HE COULD CHEW—Ronald Scott, University of Oklahoma's 137-pound Big Seven Conference champion, appears to be taking a bite out of Pete Compton's back, as he rides the Illinois grappler. Compton squirmed out of it and won this bout, as his Illini mates were losing dual encounter to Sooners. (Photo by John Nesom)

Ritenour, coached by John Moore, and Normandy have developed an intense rivalry which is evidenced by attendances of 500 or more at the dual meets between these schools. Webster Groves and Kirkwood have also had continually strong teams.

INDIVIDUAL CHAMPIONS AND PLACE WINNERS

Class	Champion	Second	Third	Fourth
95-lb.	Bergmeier (Normandy)	Miller (MM)	Wicks (Ritenour)	Schellenberg (WG)
103-lb.	Frechman (Ritenour)	Bedrosian (Normandy)	Nieters (MRH)	Geller (Univ. City)
112-lb.	Batz (WG)	Dyer (MM)	Grubbs (Ritenour)	Rigel (Ferguson)
120-lb.	Bergfeld (Ritenour)	Crider (Normandy)	Wallace (Kirkwood)	Farris (MRH)
127-lb.	Ramsey (WG)	Dillencer (MRH)	Weeke (Ritenour)	Dennison (Ferguson)
133-lb.	Frankenburger (Normandy)	Buback (WG)	Godt (Kirkwood)	Thomas (Ritenour)
138-lb.	Holscher (Kirkwood)	Moehlenpah (WG)	Doney (Normandy)	Mills (MM)
145-lb.	Hankins (Ritenour)	Hoss (WG)	Barnes (Normandy)	Alcorn (Kirkwood)
154-lb.	Kimmler (Ritenour)	Carey (WG)	Hickerson (Normandy)	Dindork (Univ. City)
165-lb.	Bonschi (Ritenour)	Dunkel (Normandy)	Irwin (Wentworth)	Parker (MRH)
175-lb.	Orlando (Ritenour)	Hansen (WG)	Garrison (Hadley)	Degerinis (MM)
Hvywt.	Edwards (Ritenour)	Dring (WG)	Yeager (Kemper)	Breitenbuecker (MRH)

TEAM SCORING

Ritenour 65, Webster Groves 49, Normandy 43, Maplewood Richmond Heights 17, Kirkwood 15, Missouri Military 15, University City 6, Ferguson 5, Wentworth 5, Kemper 4, Hadley 4, Clayton 3.

New England

By W. F. STORER, Noble & Greenough School

The sixth annual New England Interscholastic Wrestling Association Tournament was held at Browne & Nichols School, Cambridge, Mass., February 27 and 28. Twenty schools entered 124 boys in nine different weight classes.

Choate School of Wallingford, Conn., won the team championship with a total of 24 points, edging Tabor Academy of Marion, Mass., by two points.

Edward Amerantes of East Providence High, R. I., was awarded the Cy Carlson Trophy as the outstanding wrestler of the tournament.

INDIVIDUAL CHAMPIONS AND PLACE WINNERS

Class	Champion	Second	Third
115-lb.	Amerantes (E. Prov.)	Dejolie (Exeter)	Cottrell (Choate)
123-lb.	McKee (Choate)	Winthrop (St. Mark's)	Badger (N&G)
130-lb.	Moog (Roxbury)	Chamberlain (Needham)	Andrews (Milton)
137-lb.	Williams (Milton)	Donavan (Brooks)	Burns (B&N)

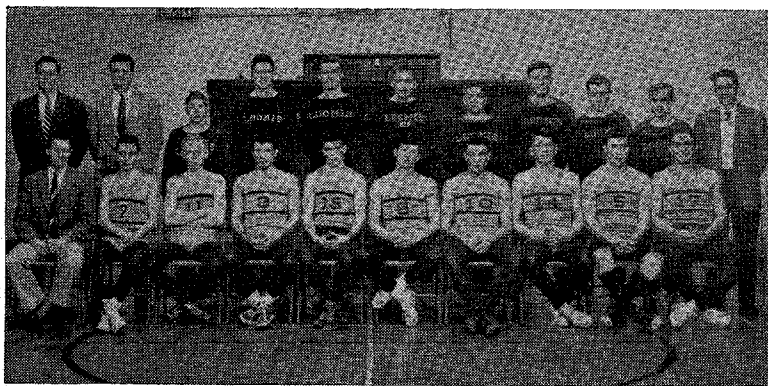

LOOMIS SCHOOLBOY CHAMPS, of Windsor, Conn.: Left to right, front row—Brevilier, White, Johnson, Cascio, Davis, Stainton, Loomis, Howard, Rice, Margolis; back row—Lutes (mgr.), Haller (ass't coach), Burns, Mayer, Fahrman, Catlin, Lawrence, Hagearty, Huckans, Mapes, Coach D'Antonio.

147-lb.	Roche (Tabor)	Lisle (Exeter)	Holbrook (Brooks)
157-lb.	Baker (Exeter)	Graves (B&N)	Miller (Tabor)
167-lb.	Foss (Choate)	Gilmore (St. Mark's)	Reagan (Tabor)
177-lb.	Ryan (Tabor)	Santaniello (Mt. Pleasant)	Pitkin (Choate)
Hvywt.	Eastman (Needham)	Gaynor (Choate)	Thompson (Belmont)

TEAM SCORING

Choate 24, Tabor 22, Exeter 17, Needham 14, Roxbury Latin 12, Milton 10, Brooks 9, St. Mark's 9, E. Providence 8, Browne & Nichols 7, Mt. Pleasant 6, Belmont Hill 3, Noble & Greenough 3, Governor Dummer 2, Wellesley 2, Kingswood 1, Perkins Institute 1.

Western New England

By JOHN CORAMIHALIS, *Tournament Chairman*

The first annual public and private school wrestling tournament, sponsored by the Grappler's Club of Springfield College, was held at Springfield College, March 7.

Seven schools were represented in the tourney. The Loomis School of Windsor, Conn., took first place honors with 50 points.

Appleton of Mt. Hermon and Howard of Loomis were outstanding in their individual weight classes.

INDIVIDUAL CHAMPIONS AND RUNNER-UPS

Class	Champion	Runner-up
115-lb.	White (Loomis)	Jacob (Worcester)
123-lb.	A. Moses (Springfield PS)	Johnson (Loomis)
130-lb.	Gregg (Worcester)	Jolicoeur (Springfield PS)
137-lb.	Davis (Loomis)	Simmerer (Mt. Hermon)
147-lb.	Stainton (Loomis)	Huckabee (Mt. Hermon)

157-lb.	Appleton (Mt. Hermon)	Karam (Springfield PS)
167-lb.	Howard (Loomis)	Miller (Darrow)
177-lb.	Rice (Loomis)	White (Mt. Hermon)
Hvywt.	Margolis (Loomis)	Rose (Cheshire)

TEAM SCORING

Loomis 50, Mt. Hermon 19, Springfield Public Schools 15, Worcester 12, Darrow 6, Cheshire 4, Kingswood 0.

New Jersey

By T. RALPH WILLIAMS, *Roselle Park High School*

Roselle Park High School culminated two undefeated seasons by winning the New Jersey state championship at the Elizabeth armory on March 7. The runner-up trophy went to Bound Brook high school, while Paulsboro high school showed real strength in taking third place.

This year the outstanding wrestler award went to Nick Biondi of Union high school.

The Section champions consisted of Bound Brook, Paulsboro, Teaneck and Roselle Park.

Approximately 30 schools are now wrestling on a varsity basis in New Jersey with all signs pointing toward an increase in the number of participating schools in the near future. Other wrestling activities in which scholastic wrestlers played a prominent part consisted of the annual Wrestling Clinic at Rutgers University, the state Novice AAU tournament at Elizabeth, the Union County Novice Wrestling tournament and the state open AAU tournament.

INDIVIDUAL CHAMPIONS AND RUNNER-UPS

Class	Champion	Runner-up
106-lb.	LaIacoma (Leonia)	Burt (Roselle Park)
115-lb.	Weiss (Union)	Frisby (Paulsboro)
123-lb.	Scharre (Washington)	Ecoresse (Springfield Reg.)
130-lb.	Gray (Newton)	Hennessey (Roselle Park)
136-lb.	Biondi (Union)	Kostalni (Newton)
141-lb.	Cornish (Washington)	Gucker (Roselle Park)
148-lb.	Amato (Bound Brook)	Williams (Roselle Park)
157-lb.	Yeats (Roselle Park)	Gentile (Paulsboro)
168-lb.	Bronico (Phillipsburg)	Quatrocchi (Paulsboro)
Hvywt.	Sandusky (Bound Brook)	DelBene (Plainfield)

Oklahoma

By JOHN DIVINE, *Coach, Perry High School*

The 1953 wrestling season was brought to a close by the 33rd Oklahoma High School State Tournament in which 15 schools qualified boys from the regional tournaments held at Perry and Bristow.

Ponca City edged Perry for the team title by scoring 27 points to 26 for the runner-up. Central of Tulsa and Webster of Tulsa tied for third with 22 each.

Doug Blubaugh, the 141-pound titlist from Ponca City, was chosen as the outstanding wrestler of the tournament.

INDIVIDUAL CHAMPIONS AND PLACE WINNERS

Class	Champion	Second	Third	Fourth
106-lb.	Carter (Webster)	Vinn (Stillwater)	Wilson (Ponca City)	Pope (Classen)

115-lb.	Hoke (Classen)	Lanning (Central)	McClung (Ponca City)	Murty (Rogers)
123-lb.	Billings (Webster)	Quance (Perry)	Walters (Stillwater)	Hixon (Classen)
130-lb.	Lyons (Bristow)	Raska (Central)	Weston (Webster)	Oden (Perry)
136-lb.	Studebaker (Perry)	Weichert (Central)	Seaborn (Ponca City)	Miller (Webster)
141-lb.	Blubaugh (Ponca City)	McQuain (Perry)	Newer (Geary)	Morris (Webster)
148-lb.	Kinyon (Stillwater)	Nowlin (Rogers)	Edgar (Perry)	Taylor (Central)
157-lb.	Sullivan (Ponca City)	Calhoun (Rogers)	Powell (Webster)	Davis (Central)
168-lb.	Pricer (Perry)	Welch (Rogers)	Mullins (Ponca City)	Timberlake (Central)
Hvywt.	Wilcox (Rogers)	Humphrey (Central)	Bowman (Ponca City)	Coln (Putnam City)

TEAM SCORING

Ponca City 27, Perry 26, Central (Tulsa) 22, Webster (Tulsa) 22, Rogers (Tulsa) 21, Stillwater 12, Classen 8, Bristow 6, Geary 3, Putnam City 2.

Oregon

By JOHN H. EGGERS, Athletic News Director, Oregon State College

Newberg high school, always a threat for the title, but never before a champion, walked off with the 1953 Oregon state high school wrestling crown, at the annual meet held on the Oregon State College campus, March 6 and 7.

The state titlists, coached by Earl Gillis, had four individual champions in rolling up 38 points and upending Hillsboro's defending kingpins and Klamath Falls, the pre-tourney favorite.

A total of 192 athletes, representing the four districts in the state, competed in the most successful tournament in Oregon mat history. Interest was high, crowds were better than ever before and Jim Dixon, Oregon State college coach and meet director, conducted the classic in workmanlike fashion.

INDIVIDUAL CHAMPIONS AND RUNNER-UPS

Class	Champion	Runner-up
93-lb.	Smith (McMinnville)	Ehlers (Hillsboro)
106-lb.	Kim (Canby)	Arnett (Oregon City)
115-lb.	Umfleet (Newberg)	Owings (Canby)
123-lb.	Green (Newberg)	Foster (McMinnville)
130-lb.	Olson (Park Rose)	Zottola (Grants Pass)
136-lb.	Dearing (Klamath Falls)	Bergan (Park Rose)
141-lb.	Stepper (Salem)	Toucher (Klamath Falls)
148-lb.	Johnson (Klamath Falls)	Casale (Park Rose)
157-lb.	Krupicka (Molalla)	Hanscomb (Medford)
168-lb.	Schnitz (Dayton)	Rogerson (Bend)
178-lb.	Staley (Newberg)	Crawley (Dayton)
Hvywt.	Clock (Newberg)	McAdams (Newberg)

TEAM SCORING

Newberg 38, Klamath Falls 30, Park Rose 20, Salem 17, Canby 14, Hillsboro 13, Dayton 13, Oregon City 12, McMinnville 12, Albany 8, Grants Pass 7, Springfield 5, Lebanon 4, Tigard 2, Beaverton 2, Corvallis 1.

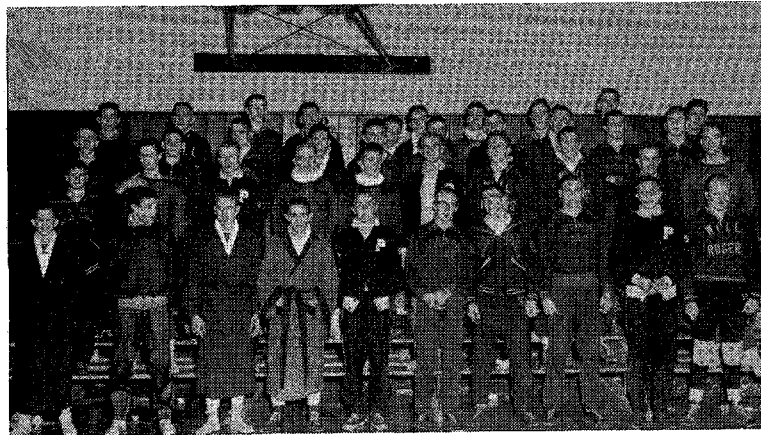

OKLAHOMA HIGH SCHOOL PLACE WINNERS: Left to right, front row (champs) Carter, Hoke, Billings, Lyons, Studebaker, Blubaugh, Kinyon, Sullivan, Pricer, Wilcox; second row (runners-up)—Venn, Lanning, Quance, Raska, Weichert, McQuain, Nowlin, Calhoun, Welch, Humphrey; third row (3rd places)—Wilson, McClung, Walters, Weston, Seaborn, Newer, Edgar, Powell, Mullins, Bowman; back row (4th places)—Pope, Murty, Hixon, Oden, Miller, Morris, Taylor, Davis, Timberlake, Coln.

Utah

By MEL WOOD, Coach, Weber High School

Weber High School won the Utah state wrestling championship for the fifth consecutive year. The meet was held at Utah State College and attracted participants from 19 schools as compared with 14 a year ago. A total of 96 men qualified for the finals.

Trophies were awarded to the champion and Box Elder High, the runner-up. Individual winners received gold medals, second place winners silver medals, third place and fourth place winners bronze medals.

INDIVIDUAL CHAMPIONS AND PLACE WINNERS

Class	Champion	Second	Third	Fourth
95-lb.	Bingham (Weber)	Carter (Box Elder)	Overson (Delta)	Guber (Hurricane)
103-lb.	Uyematsy (Box Elder)	Thomasson (Davis)	A. Galvez (Weber)	Johnson (East)
112-lb.	Kubota (Ogden)	W. Galvez (Weber)	Cummings (Millard)	Carpenter (Cedar)
120-lb.	Cox (Provo)	Hansen (Weber)	Johnson (Millard)	Knight (Uintah)
127-lb.	Callister (Delta)	Nielson (Payson)	Stettler (Ogden)	Prows (Millard)
133-lb.	Knight (Delta)	Windley (Payson)	Knill (East)	Hatch (Box Elder)
138-lb.	Kunzler (Box Elder)	Thompson (Ogden)	Roberts (Payson)	George (Millard)
145-lb.	Smoot (Box Elder)	Dixon (Carbon)	Ward (Davis)	Ward (Beaver)

154-lb.	Francis (Weber)	Smith (Cedar City)	Nielson (Delta)	Haycock (East)
165-lb.	Marriott (Weber)	Lee (East)	Prince (Cedar City)	Whitehead (Jordan)
175-lb.	Ashley (Jordan)	Smith (Millard)	Taylor (East)	Knuz (Hurricane)
Hvywt.	Anderson (Weber)	Ramage (Carbon)	Tanner (East)	Loyde (Wasatch)

TEAM SCORING

Weber 37, Box Elder 28, Delta 18, East 18, Millard 15, Ogden 15, Jordan 11, Payson 11, Carbon 9, Cedar City 8, Davis 8, Provo 6, Hurricane 2, Wasatch 2, Beaver 1, Uintah 1.

Virginia

By WILLIAM P. MARTIN, *Granby High School, Norfolk, Va.*

Eighty-nine wrestlers competed in the State High and Prep School Tournament held at the University of Virginia on March 27 and 28. Granby High of Norfolk beat out its cross-town neighbor, Maury High School, for the team championship.

The individual titles were more evenly distributed than ever as Granby, Maury, Virginia School for the Deaf & Blind, South Norfolk, Jefferson (Roanoke) and Warwick each took one or more individual championships.

INDIVIDUAL CHAMPIONS AND PLACE WINNERS

Class	Champion	Second	Third	Fourth
95-lb.	Kazzie (Maury)	Bateman (S. Norfolk)	DeJacimo (Granby)	Gray (Norview)
103-lb.	Lily (V.S.D.B.)	Demming (Maury)	Jackson (S. Norfolk)	Trowsdell (Warwick)
112-lb.	Piercy (Granby)	Webster (Jefferson)	Pace (Warwick)	Cotton (S. Norfolk)
120-lb.	Carson (Granby)	Willson (Maury)	Fary (V.S.D.B.)	Powell (Fleming)
127-lb.	Taylor (Granby)	Farabee (Maury)	Saul (Jefferson)	Reveal (V.S.D.B.)
133-lb.	Weatherly (S. Norfolk)	Longton (Granby)	Cooke (Maury)	Large (Kempsville)
138-lb.	Vandevender (Granby)	Seay (Maury)	Moreland (Warwick)	Eastwood (Kempsville)
145-lb.	Swindell (Granby)	Wright (Fleming)	Clements (Norview)	Walls (Maury)
154-lb.	Bowling (Jefferson)	Larson (Maury)	Hegler (Fleming)	Baker (S. Norfolk)
165-lb.	Bolling (Jefferson)	Sanders (Maury)	Johnson (Warwick)	Moore (Granby)
175-lb.	Harless (Granby)	Cruickshank (Fleming)	Coffield (S. Norfolk)	Scarborough (Maury)
Hvywt.	Jordan (Warwick)	Goodwyn (Granby)	Wiley (Jefferson)	Upton (Maury)

TEAM SCORING

Granby (Norfolk) 65, Maury (Norfolk) 45, Jefferson (Roanoke) 23, South (Norfolk) 19, Warwick 15, Fleming (Roanoke) 13, Virginia School for Deaf and Blind 10, Kempsville (Norfolk) 4, Norview (Norfolk) 2.

Wisconsin

By GEORGE MARTIN

Although hard pressed, Milwaukee South won the 1953 state interscholastic title, to set a new record of our consecutive state championships. South scored 29 points to runner-up Madison East's 26.

The spread in points scored was far less than in recent years, with individual titles distributed among five schools, and boys from ten schools taking either gold or silver medals.

INDIVIDUAL CHAMPIONS AND PLACE WINNERS

Class	Champion	Second	Third
103-lb.	Pyka (Mil. South)	Hamel (Wis. High)	Lasecki (Stevens Pt.)
112-lb.	Krzkowski (Mil. South)	Gorman (Mad. East)	Warner (Stevens Pt.)
120-lb.	Hammes (Mad. East)	Esoueda (Mil. South)	Kobishop (Stevens Pt.)
128-lb.	Dent (Mil. South)	Poole (Mad. East)	Erdman (Janesville)
136-lb.	Olstadt (Mad. East)	Ol'on (Wil. Wash.)	Bemke (Stevens Pt.)
145-lb.	Buntrock (Mil. Wash.)	Samuels (Beloit)	Gaunnitz (Mad. East)
155-lb.	Olsen (Racine Park)	Barbian (Mil. B.T.)	Wild (Mad. East)
165-lb.	Juszcak (Mil. Pulaski)	Gupton (Beloit)	Milsted (Mad. East)
180-lb.	Juszcak (Mil. Pulaski)	Engen (Mad. East)	Gladney (Beloit)
Hvywt.	Sobczak (Mil. South)	Pratt (Beloit)	Cole (Mad. East)

TEAM SCORING

Milwaukee South 29, Madison East 26, Beloit 16, Milwaukee Pulaski 13, Stevens Point 12, Milwaukee Washington 10, Madison West 9, Racine Park 7. Other teams scoring: Milwaukee Boy's Tech, Madison Wisconsin High, Janesville, Racine Horlick, Valders, Luxemburg.

Academy School Tournament

By FREDERICK R. KUHN, *Coach, Mercersburg Academy*

Winning or sharing the top the past five years, the Hill School again won the Academy School Tournament held at Lehigh University, with a total of 28 points and three individual champions.

Seventy-four candidates, representing 12 schools, scored 35 falls in wrestling a total of 90 bouts to determine the individual and team titles.

The coaches trophy for the outstanding wrestler was awarded to Richard Green, wrestling in the 167-pound class, representing Mercersburg Academy.

INDIVIDUAL CHAMPIONS AND PLACE WINNERS

Class	Champion	Second	Third
115-lb.	Perry (Milton Her.)	Morgau (Wyoming)	Fitch (Hill School)
123-lb.	Kelley (Milton Her.)	McKee (Choate)	Krishart (Stevens)
130-lb.	Pearson (Hill School)	Bare (Milton Her.)	Reiss (Mercersburg)

137-lb.	Pepe (Wyoming)	Smith (Mercersburg)	Reed (Stevens)
147-lb.	Macano (Stevens)	Fillius (St. Albans)	Draper (Mercersburg)
157-lb.	Huntsman (Hill School)	Smethurst (St. Albans)	Krapf (Stevens)
167-lb.	Green (Mercersburg)	Woodin (Wyoming)	Hetrick (Stevens)
177-lb.	Stremic (Wyoming)	Richards (Milton Her.)	Provan (Stony Brook)
Hvywt.	Wynne (Hill School)	Gaynor (Choate)	Irvin (Stevens)

TEAM SCORING

Hill School 28, Milton Hershey 27, Wyoming Seminary 24, Stevens Trade 23, Mercersburg Academy 21, St. Albans School 10, Choate School 9, New York Military 4, Brooklyn Poly Prep 3, St. Pauls School 3, Stony Brook School 3.

Wyoming

The seventh annual Wyoming High School Wrestling tournament was held at the University of Wyoming on March 13 and 14.

Team trophies were presented to the five top teams. Cheyenne won the team championship with a total of 37 points, followed closely by Powell with 35 and Rock Springs 32.

Individual metals were presented to the champions, second, third and four place winners. Roy Taylor of Rock Springs received the trophy for the meet's outstanding wrestler.

TEAM SCORING

Cheyenne 37, Powell 35, Rock Springs 32, Laramie 27, Cody 25, Newcastle 15, Casper 12, Worland 7, Wheatland 3, Mountain View 2.

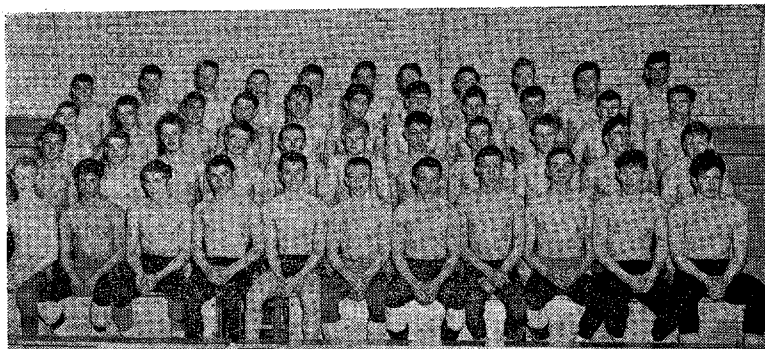

WYOMING HIGH SCHOOL MAT STARS: Left to right, front row (champs)—Ballinger, Rodrigues, Peet, W. Clark, Wagner, Wintermote, McGahey, Giesler, Taylor, Fuson, Peterson; second row (runners-up)—N. Martinez, Baker, D. Clark, Anderson, A. Jereb, Richmond, Bustos, Pond, Allen, Daly, Easter; third row (3rd places)—Jolliffe, Folster, Stringer, Robbins, Moeller, B. Martinez, Jackson, Ellis, Christenson, Stutzman, Nelson; back row (4th places)—Fernandez, Ackley, Neal, Starr, Janssen, Miller, Argeris, J. Jereb, B. Clark, Morgan, Cook.

OFFICIAL NCAA WRESTLING GUIDE

OFFICIAL WRESTLING RULES

OF THE

NATIONAL COLLEGIATE
ATHLETIC ASSOCIATION

B. R. PATTERSON, EDITOR

NCAA Wrestling Rules Committee

HENRY STONE, <i>Chairman</i>	University of California
FENDLEY COLLINS	Michigan State College
L. L. MENDENHALL	Iowa State Teachers College
JAMES J. REED	Princeton University
P. G. ROBERTSON	University of Oklahoma
RAYMOND SPARKS	Springfield College
J. F. WAGNER	Colorado A&M College
H. D. KESTER, NFSHSAA	West High School, Cleveland, O.



WRESTLING RULES COMMITTEE of the National Collegiate Athletic Association:
Left to right—H. D. Kester, J. F. Wagner, P. G. Robertson, James J. Reed, Henry Stone, L. L. Mendenhall, Raymond Sparks, Fendley Collins.

Official NCAA Wrestling Rules 1954

RULE 1—ELIGIBILITY

1. Each contestant must be an Amateur as defined in the rules of the National Collegiate Athletic Association and be eligible according to the rules and regulations of the college or university which he represents.

2. In addition to the above, participants in the NCAA tournament must represent institutions which are active individual or allied members of the NCAA and must conform to the rules of eligibility adopted by the NCAA, to apply to all annual championship meets conducted by this Association. These rules will be printed and explained in the entry blanks for the National Collegiate Wrestling tournament. Representatives of institutions which are included in the Allied Membership of the NCAA may participate, provided the representatives' institution pays into the NCAA treasury a fee of \$10.00. In addition to the above, the usual individual entry fee of \$2.00 is charged by the National Collegiate Wrestling Rules Committee.

Note. See Rule 5, Section 4.

3. All colleges, universities and institutions of learning in the United States with acceptable scholastic and athletic standards may be elected to membership in the NCAA. To comply with "acceptable *scholastic* standards" the institution must be on the approved list of the accepted accrediting agency of the district in which the institution is located.

An institution is considered as having "satisfactory *athletic* standards" on approval of its standards by a two-thirds majority of the active members of the NCAA in the Association District in which the institution is located. Further information regarding application for membership may be obtained from the Executive Director of the NCAA, Walter Byers, Fairfax Building, 11th & Baltimore, Kansas City, Mo. At least 30 days should be allowed for the above procedure.

RULE 2—REPRESENTATION

1. An institution shall be represented by only one contestant in each weight class.

2. No contestant shall be allowed to represent his institution in more than one class in each meet.

3. A representative may not accept a forfeit in one weight class and compete in another class.

4. A contestant who weighs-in for one weight class may be shifted to a higher weight class.

5. **Tournaments.** All entries to the NCAA meet which are received after the deadline date, shall be charged a double entry fee. The deadline date shall be nine days in advance of the first tournament session.

RULE 3—MATS AND COSTUMES

1. The wrestling area of the mat shall not be less than 24 feet by 24 feet. Supplementary mats, 5 feet in width, shall extend entirely around the mat proper. The thickness of the mats shall not be less than 2 inches nor more than 4 inches.

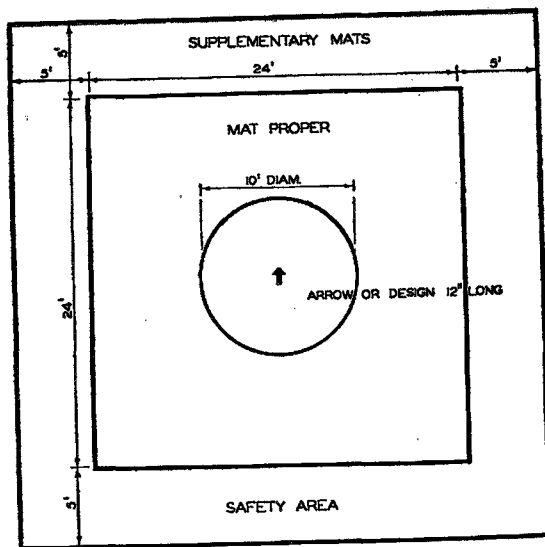

RECOMMENDED MAT SIZE.

All lines are 2" wide.

It is recommended that a moleskin, canton flannel, rubber, or plastic mat cover be provided sufficiently large to cover the mat proper and all supplementary mats. This cover should be stretched tightly and be held in place by ropes, or tape fastening the mat cover to the under side of the supplementary mats, or by lacing the cover underneath the mats. The wrestling area should be marked on mat cover by painted lines two inches in width. At the center of the mat proper there shall be similarly painted a circle ten feet in diameter. Whenever the match is started or resumed, the contestants shall be within this circle and throughout the match contestants are expected to wrestle within this circle so far as possible. There shall be placed at the center of the cover a design, at least twelve inches long, placed perpendicular to and pointing away from the timer's table. This design designates the place where matches are to start and the direction wrestlers are to face when starting the wrestling from the referee's position on the mat.

2. The uniform shall consist of:

- A. Full length tights and close fitting outside short trunks.
- B. Light heelless gymnasium shoes reaching above the ankle and laced by means of eyelets.

C. Shirts, if required by the home management. The shirt shall be sleeveless without fasteners at the shoulder and fastened down at the crotch. They shall not be cut away excessively at the arms, but *must* conform to the pattern illustrated in Fig. 1 and Fig. 2 (picture of legal shirt, back and front view). The visiting team must be notified in sufficient time to be able to comply with the home team's request.

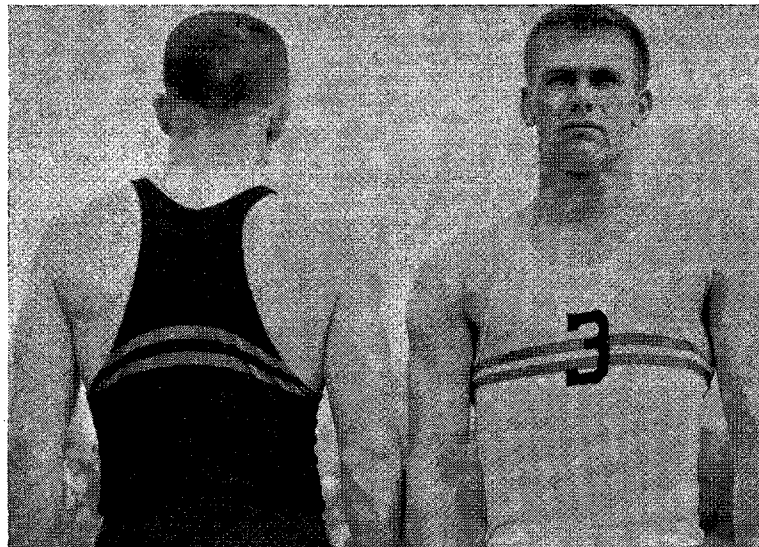

Nos. 1 and 2—FRONT AND REAR VIEW OF SHIRT
This shows the front and rear view of the official shirt.

The Wrestling Rules Committee strongly recommends that protective headgear be used in all practice and competition. Headgears if worn shall have all rivets or metal surfaces covered with protective material. Contestants may wear ear protection or acceptable helmets but opponents shall be notified in advance of the meet.

3. It happens occasionally that two contestants look so much alike and are dressed so similarly that it is very difficult for the Referee and spectators to distinguish them. In all dual meets or tournaments, the home management shall have immediately available some provisions for clearly identifying the contestants. Such provisions may be by means of colored anklets, numbers, or any other plan which will accomplish the purpose.

4. **Equipment.** Any mechanical device which does not allow normal movement of the joints and prevents one's opponent from applying normal holds shall be barred. Any legal device which is hard and abrasive must be covered and padded. The legality of the device shall rest with the official of the meet.

RULE 4—WEIGHT CLASSIFICATIONS

1. Competition shall be divided into eight weight classes as follows:

123 lbs.	157 lbs.
130 lbs.	167 lbs.
137 lbs.	177 lbs.
147 lbs.	Unlimited

The 115-lb. and/or 191-lb. classes may be officially included in the weight classification provided either or both are adopted by individual conferences. Interconference meets shall be contested in the original (8) weights.

For the NCAA tournament the 115 and 191-lb. classes will be included. These weights will count in the scoring of the team championship.

RULE 5—WEIGHING-IN AND DESIGNATION OF CONTESTANTS

1. Time

A. **TOURNAMENTS.** Each day of the tournament contestants will weigh-in a maximum of five hours and a minimum of four hours before the meet is scheduled to begin.

B. The contestant who is to represent his institution must be named before the drawings are made.

C. **DUAL MEETS.** Contestants may weigh-in a maximum of five hours and a minimum of one-half hour before the meet is scheduled to begin. The exact maximum time shall be decided by mutual agreement of the competing teams. The home team's representative shall be sent onto the mat first, and he cannot be withdrawn or replaced.

D. **SUPERVISION.** The Referee or other authorized person shall supervise the weighing-in of contestants.

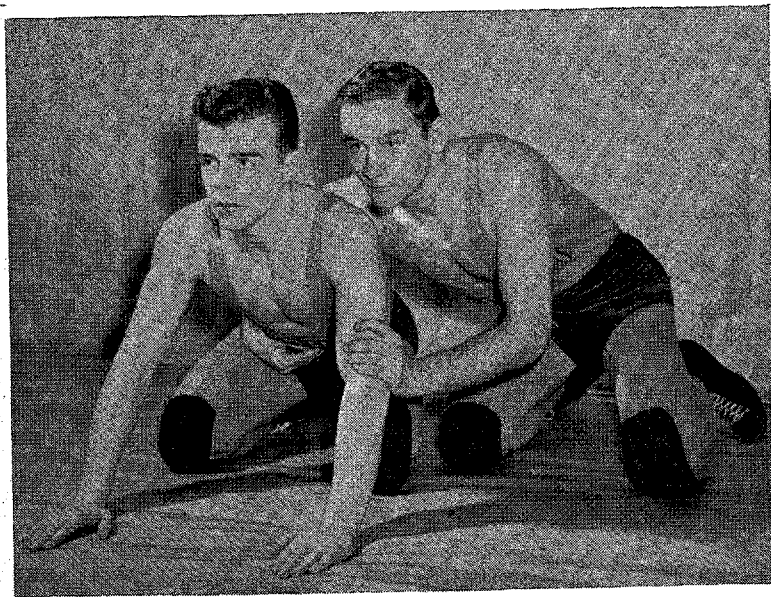

No. 3—LEGAL "REFEREE'S POSITION ON MAT."

This position is shown as required in Rule 10, Section 4. Note particularly that offensive wrestler's right leg is outside of defensive wrestler's left leg.

E. Teams may weigh-in on home scales by mutual agreement of coaches and shall furnish weight list with actual weights listed.

2. Weight Allowance

A. **DUAL MEETS.** In all dual meets, net weights shall be required. No over-weight is permitted nor should it be requested.

B. **TOURNAMENTS.** In tournaments one pound allowance shall be allowed after the first day.

3. **Failure to Make Weight.** Any contestant failing to make weight at the minimum time shall be rejected.

4. **Communicable Disease to Disqualify.** At the time of the weighing-in on the opening day of the annual National Collegiate Tournament, a physician or physicians shall be present to examine all contestants for communicable diseases and shall disqualify any contestant who, in their judgment, will endanger other participants. In other meets it is recommended that a medical examination of all contestants be made at the time of the weighing-in, and the presence of a communicable disease or any other condition, which in the opinion of the examining physician makes the participation of that individual inadvisable, should be considered full and sufficient reason for disqualification.

5. No substitution is allowed in dual meets or tournaments for injured contestants.

6. Defeat due to injury in a tournament does not eliminate a man for third place competition.

RULE 6—CONDUCT OF TOURNAMENTS

1. **Places Scored.** In all tournaments four places shall be awarded as follows: The loser in the final first place match shall automatically take second place; the winner of the final consolation match shall be awarded third place and the loser fourth place.

2. **Drawings.** Drawings shall be made in accordance with the graphic illustration as provided in Section 6 and 7 of this rule.

3. **Seeding.** Whenever there are two outstanding contestants in any class, the name of one of these contestants shall be placed in the upper half of the drawing bracket and the name of the other in the lower half. In case several seeded men are of equal ability, their seeded positions shall be determined by drawing.

If there is one outstanding wrestler in any class and also two others who are distinctly superior to the remainder in that class, those wrestlers should be seeded in different quarter brackets of the opposite half bracket from the outstanding wrestler. A seeded contestant shall have the same opportunity to draw for the bye as other contestants in his brackets.

In the Annual National Collegiate Tournament, whenever possible, contestants from the same geographical location or conference who have previously met during the season shall be drawn so as to prevent them from meeting in the first round.

4. **Method of Drawing.** Immediately after the expiration of the minimum weighing-in time, drawing shall be made.

5. **Byes.** When the number of competitors is not a power of two (that is, 4, 8, 16, 32, 64) there shall be "byes" in the first round. The number of pairs which meet in the first round shall be equal to the difference between the number of competitors and the next lower power of two. There will be no byes after the first round and no further drawing is necessary for the first

place or consolation rounds. The byes, if even in number, shall be equally divided between top and bottom. If the number of byes be uneven, there shall be one more bye at the bottom than at the top, as shown in Section 6 of this rule.

Any conference or other tournament may be conducted under any bracketing that is agreed upon by the participating schools.

6. Graphic Illustration of Drawings and Seeding.

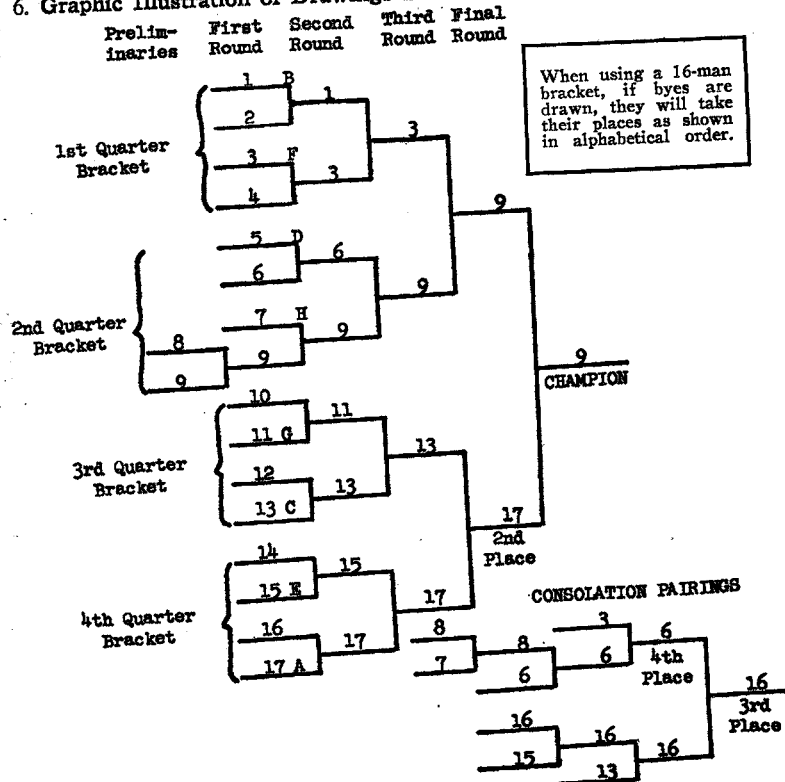

- Number 1 seeded man draws for possible positions 5, 6, 7, 8, 9, in 2nd Quarter Bracket.
- Number 2 seeded man draws for possible positions 10, 11, 12, 13, in 3rd Quarter Bracket.
- Number 3 seeded man draws for possible positions 14, 15, 16, 17, in 4th Quarter Bracket.
- Number 4 seeded man draws for possible positions 1, 2, 3, 4, in 1st Quarter Bracket.
- Number 5 seeded man draws for position in opposite half of Quarter Bracket #1.
- Number 6 seeded man draws for position in opposite half of Quarter Bracket #4.
- Number 7 seeded man draws for position in opposite half of Quarter Bracket #3.
- Number 8 seeded man draws for position in opposite half of Quarter Bracket #2.

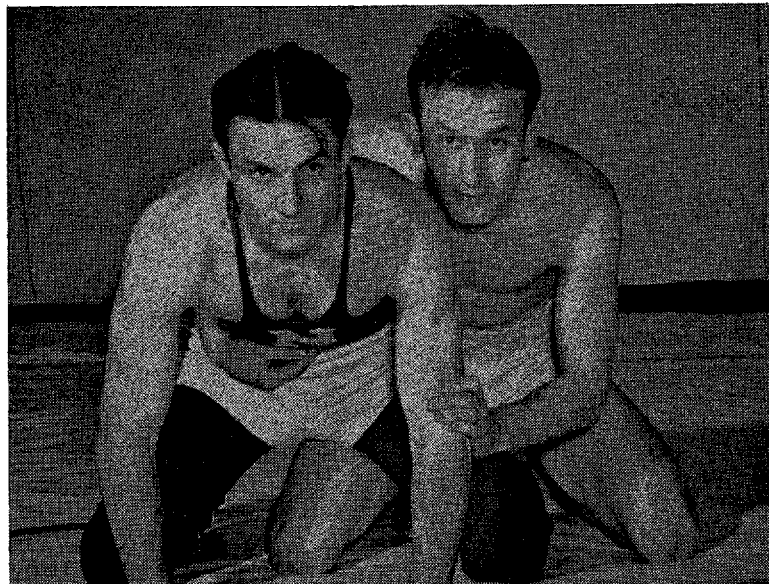

No. 4--ILLEGAL "REFEREE'S POSITION ON MAT."

This position is illegal because offensive wrestler's right knee is inside of defensive wrestler's left leg.

7. Contestants Eligible for Third Place Matches.

A. Immediately after completion of the first semi-final match in each weight the third place consolation rounds shall start between all contestants defeated by the winner of this semi-final match. (See "B" following.)

After completion of the second semi-final match in this same weight the same plan shall be followed as indicated in preceding paragraph. The winners of the third place consolation rounds in each of the two half-brackets in each weight class, meet in the final consolation match to determine the third and fourth place winner.

B. When only two contestants have been defeated by the winner of any semi-final match the two defeated contestants shall compete and the winner of the match shall meet the corresponding winner from the other half-bracket to decide the third and fourth place awards. When more than two contestants have been defeated by the winner of any semi-final match, preliminary third place matches will be necessary and should be conducted in accordance with the original first round drawings; therefore, those eligible for the third place consolations should be matched in the order in which they were defeated by the finalists in this half-bracket. The eligible contestants are designated in Section 7A of this Rule.

8. Example. Referring to the Graphic Illustration under Section 6, those eligible for the third place rounds in the upper half-bracket 8, 7, 6, 3, we

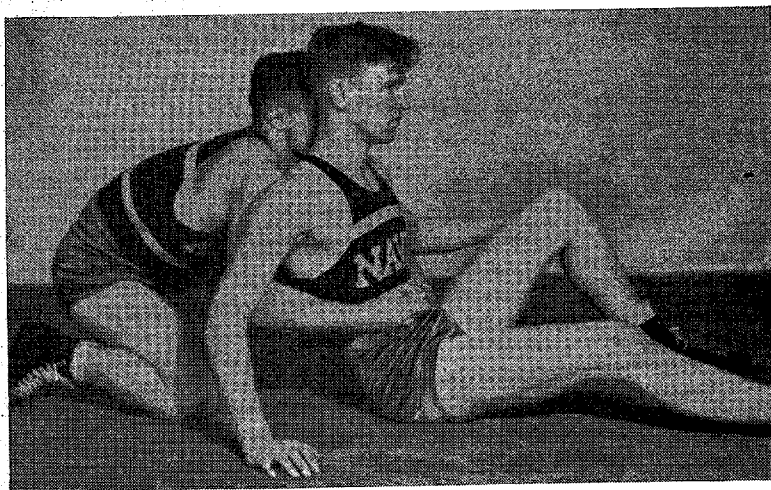

No. 5—ILLEGAL USE OF HANDS IN BODYLOCK.

Offensive wrestler is not allowed to lock hands, wrists or arms around body while defensive wrestler has hands and knees on mat. (See Rule 10, Section 1.)

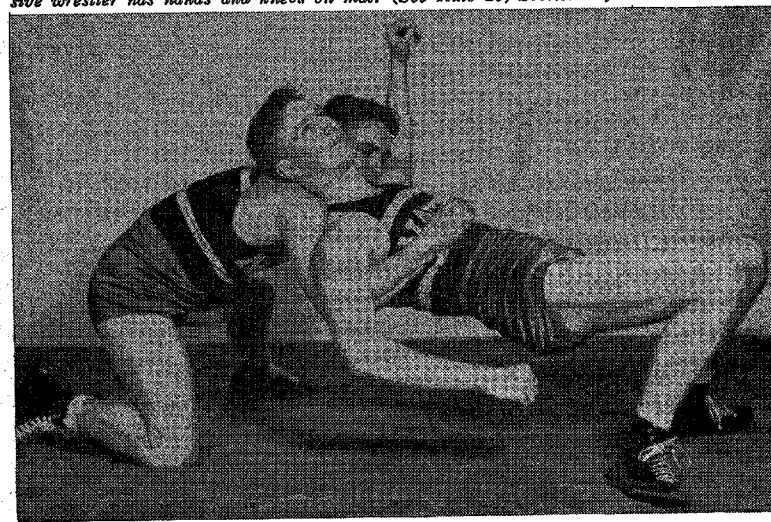

No. 6—LEGAL USE OF THE HANDS IN WAISTLOCK.

This shows the legal use of the hands of the top man. The defensive contestant's weight is clearly on his feet, and his hands are off the mat.

will assume that 8 wins from 7 and then 6 wins from 8 and then 6 defeats 3.

In the lower half-bracket three contestants 16, 15 and 13 have been defeated by the finalist 17 and therefore, only two matches are necessary. We will assume 16 defeats 15 and later defeats 13. He meets 6 in the final consolation match in this weight. The winner 16 is awarded third place and the loser 6 fourth place. All third place matches shall be run off prior to the first place finals matches.

9. The Wrestling Rules Committee recommends that medals and team trophies be formally presented in a ceremony made as impressive as possible.

RULE 7—CONDUCT OF MATCHES

1. All regular matches shall consist of three three-minute periods. The first period will start with both contestants standing in opposite corners of the mat. The wrestlers will come forward, shake hands with the right hand, pass each other, turn to the left at the edge of the circle and, when the Referee blows his whistle, begin wrestling. **A fall during this or either subsequent period terminates the match.** If neither contestant secures a fall in this first period, the Referee shall recess the match and place the wrestlers in the Referee's position (Rule 8, Sec. 1) with the appropriate contestant in the position of advantage (Rule 7, Sec. 4). The second three-minute period shall be started immediately by the Referee's whistle. If no fall occurs during this second period, upon its expiration the Referee shall again recess the match, place the contestant who started the second period in the position of advantage underneath and start the third period as before. If no fall occurs during this final period, upon termination of the match the Referee shall award the contest as provided (Rule 9, Sec. 6).

2. **Intermission.** Each recess between the periods of any match shall be only such time as is required by the Referee to bring the contestants into the proper position for the next period. No rest shall be permitted except for injury. (See Rule 12, Sec. 1.)

3. **Consolation Matches.** Consolation matches shall consist of three two-minute periods conducted in the same manner as regular matches in tournaments.

4. Choice of Position.

A. **DUAL MEETS.** Immediately before the contest starts the Referee shall call the captains to the center of the mat and decide by the toss of a coin which team has the choice of position at the start of the second period in each weight class. The winner of a toss may choose the odd or even weight class. A choice of odd or even matches in dual meets is not altered in case of a fall, default or forfeit.

B. **TOURNAMENT.** Immediately following the end of the first period the Referee shall determine which wrestler has the choice of position at the start of the second period, by the toss of a coin.

RULE 8—DEFINITIONS

1. **Referee's Position on the Mat.** The defensive contestant must:

- A: Face in the direction indicated by arrow or design at center of mat.
- B: Place both knees on the mat with the lower legs parallel, feet are considered part of the lower leg.
- C: Toes neither turned in, out or under in an exaggerated position.
- D: Knees must not be apart more than natural shoulder width.

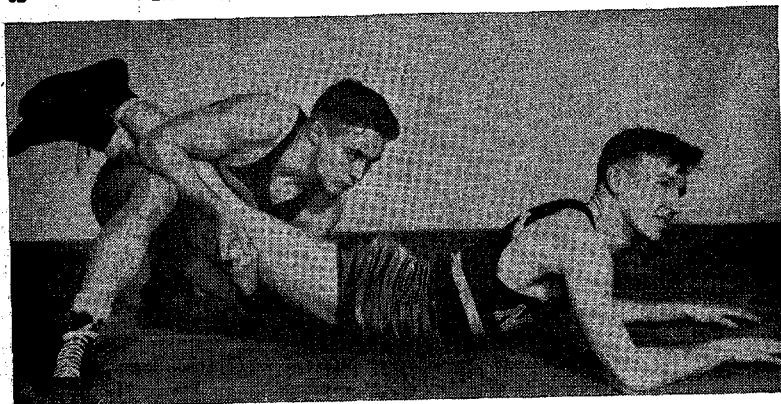

No. 7—ILLEGAL USE OF THE HANDS IN LEGLOCK ON MAT.

The position is illegal because of Rule 10, Section 4, which forbids interlocking of fingers, hands or arms around body or legs while contestants are on mat.

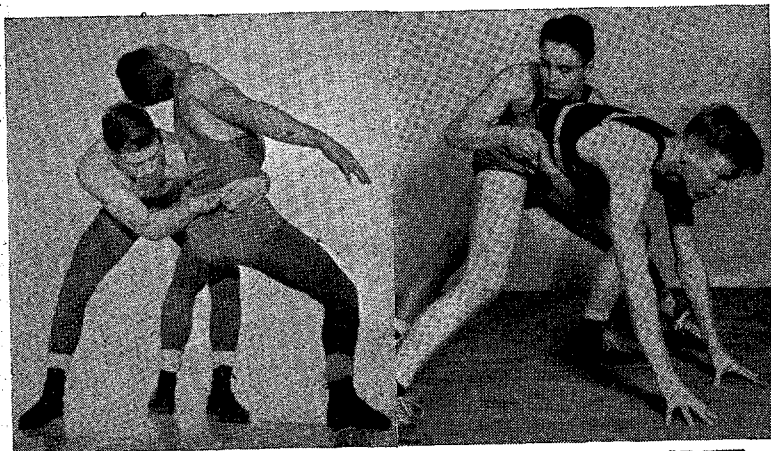

No. 8—LEGAL USE OF HANDS IN BODYLOCK.

This complete bodylock is legal because defensive wrestler is in a standing position. This hold would be illegal if defensive wrestler had both knees on mat. (See Rule 10, Section 1A.)

No. 9—ILLEGAL USE OF THE WAISTLOCK.
(MAN IS NOT CLEARLY UPON HIS FEET.)

This is illegal if the man is coming up from the mat. This may be permitted momentarily when going from a standing position to the mat. Referees are to allow reaction time only.

E. Heels of both hands must be on mat not less than 12 inches in front of the knees.

The offensive contestant must:

A. Be slightly over his opponent at his left (or right) side with his head along the midline of his opponent's back.

B. Right or left arm resting loosely around opponent's body at the waistline and the open hand palm up, in contact and centered on opponent's navel.

C. Right or left hand resting loosely on opponent's elbow. Thumb may be behind, in front or at side of elbow.

D. Both knees shall be on the mat with the nearest knee outside of and even or ahead of the opponent's foot, but not touching either foot or leg.

2. **Time Advantage.** The offensive wrestler who has control in an advantage position over his opponent is gaining time-advantage. Each wrestler has a time-keeper who records his accumulated time-advantage throughout the match. At the end of the match the Referee subtracts the lesser time-advantage from the greater. If the contestant with the greater time-advantage has less than one minute of net time-advantage, he is awarded no points by the Referee. If he has one full minute of net time-advantage, but less than two minutes he is awarded one point. If he has two full minutes or more, he is awarded two points. No contestant may be awarded more than two points for time-advantage in any one match. The contestant with the lesser time advantage receives no points even though he has accumulated several minutes of time in the advantage position.

3. **Position of Advantage.** A position in which a contestant is in control of his opponent.

4. **Take-Down.** Whenever a contestant brings his opponent to the mat and gains control while all the supporting points of the offensive wrestler's body are in the wrestling area, he has earned the position of advantage or a take-down. The offensive wrestler is entitled to this advantage until such time as his opponent gains a neutral or reversal within the boundary of the mat proper.

Note 1. The supporting parts of the defensive wrestler's body are any and all parts touching the mat at that time. The supporting parts of the offensive wrestler's body are the parts of the body touching the mat other than the parts with which he is holding his opponent. (The offensive wrestler's usual points of support are the knees or the side of one thigh and buttocks.) The offensive wrestler must have control of his opponent and must have brought him to the mat to constitute a "take-down."

5. A reversal occurs when the defensive man goes behind his opponent and gains control, either on the mat or standing.

6. An escape occurs when a defensive wrestler attains a neutral position, within the boundaries of the mat.

7. Neutral position is a position in which neither wrestler has control.

8. Contestants are "out of bounds" when any supporting part of either wrestler touches or is over the boundary line with the following exceptions:

A. When a take-down is being attempted, wrestling shall continue as long as the supporting points of *either* wrestler remains within the boundary lines of wrestling area.

B. When a fall is imminent, wrestling shall continue as long as the head and both shoulders of the defensive wrestler are within the boundary line.

9. **Resumption of Wrestling After Out of Bounds.** The position to be assumed by the contestants at the resumption of the match shall be neutral or referee's position on the mat as determined by the position held upon

going out of bounds; except when a penalty involves change of position. Resumption of a match after accidental injury is the same as for the resumption of wrestling after out of bounds.

RULE 9—SCORING

1. **Falls.** The area of the scapula is considered the pinning area of the body.

A. **PIN FALLS ONLY SHALL COUNT.** (Flying or rolling falls shall not be considered.) Any part of both shoulders or area of scapula held in contact with the mat for an appreciable length of time constitutes a fall. (By an appreciable length of time is meant the Referee's silent count of two seconds or one thousand and one, one thousand and two.) The two-second count shall start only after the Referee is in such position that he knows positively that both shoulders of either wrestler are in contact with the mat, after which shoulders must be held in continuous contact with the mat for two seconds before a fall shall be awarded.

(1) A fall shall not be awarded when one or both shoulders or the head of the defensive contestant are *out of bounds*. (See Rule 8, Sec. 8B.)

(2) If the defensive wrestler is handicapped by having any portion of his body off the mat no fall shall be awarded and out of bounds shall be declared.

(3) When the match is stopped for out of bounds in a fall situation, the

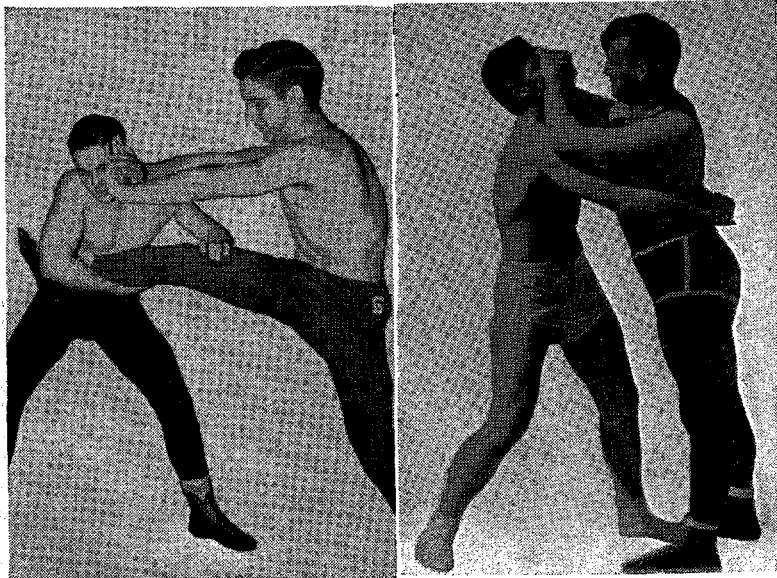

No. 10—LEGAL BLOCKING ON FACE (ON CHIN).

Blocking on chin or forehead is legal but is not legal over face proper; that is, over mouth, nose or eyes.

No. 11—ILLEGAL BLOCKING ON FACE (ON FACE PROPER).

This form of blocking is illegal because it is over mouth, nose and eyes; in contrast to position in No. 10.

match shall be resumed in the referee's position on the mat. (See Rule 8, Sec. 1.)

2. **Near Fall.** A near fall is a situation in which the offensive wrestler has control of his opponent in a pinning combination and both shoulders are held to the mat for the silent count of one second.

Whenever all the provisions of the above rule are complied with and both shoulders of the defensive wrestler are held continuously within approximately two inches of the mat for two full seconds, a near fall shall be scored.

3. **Predicament.** A predicament is a situation in which the offensive wrestler has control of his opponent in a pinning combination and a fall or near fall is imminent.

A. When both shoulders of the defensive wrestler are held in contact with the mat for too short a time to award a near fall, a predicament shall be scored.

B. When both shoulders of the defensive wrestler are held continuously within approximately four inches of the mat or less but not sufficiently close to award a near fall, for two full seconds or more, a predicament shall be scored.

C. When one shoulder of the defensive wrestler is touching the mat and the other shoulder is held within an angle of 45° or less with the mat, but not sufficiently close to award a near fall, for two seconds or more, a predicament shall be scored.

D. Only a wrestler with the advantage who has his opponent in a pin hold may score a near fall or predicament. Bridgebacks in body scissors are not considered near fall or predicament situations, although a fall may be scored.

E. Regardless of the length of time a defensive wrestler may be held in a somewhat dangerous position, no predicament or near fall may be scored except as provided in Rule 9, Secs. 1 and 2.

4. A near fall or predicament situation is ended:

A. When the defensive man escapes to neutral position or reverses position.

B. When he assumes the defensive "referee's position on the mat."

C. When he secures a position of defensive value equal to the defensive, "referee's position on the mat."

5. **Award of Points for Predicament or Near Fall.** The referee must not signal a "predicament or near fall" until the situation is ended.

Nothing in the above shall prevent repeated efforts by the offensive wrestler to pin his opponent but, regardless of the number of predicaments or near falls, he may secure in any one situation he is credited with a maximum of one point. If he has scored a predicament and two points if he has scored a near fall.

6. Decisions

A. **DUAL MEET MATCHES.** If no fall has resulted after the expiration of the three regular periods of any match provided in Rule 7, Sec. 1, the Referee shall award the match to the contestant *who has scored* the greater number of points. If there is a tie in number of points scored the Referee shall declare the match a draw.

B. **TOURNAMENT MATCHES.** In tournament competition when there is a tie in points the Referee shall award the match to the contestant who has shown superior wrestling ability.

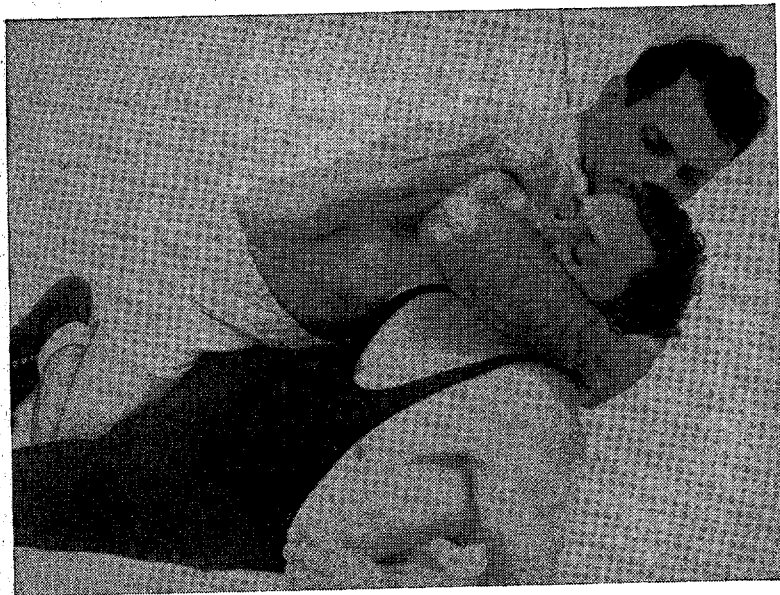

No. 12—ILLEGAL FACE HOLD.

Shows a hold commonly used but which is contrary to both the letter and spirit of amateur wrestling rules. It is frequently used momentarily in order to prevent defensive wrestler from coming out from underneath or to bring defensive wrestler back into position for a fall. Referee should see that offensive wrestler does not secure unfair advantage by means of this illegal action.

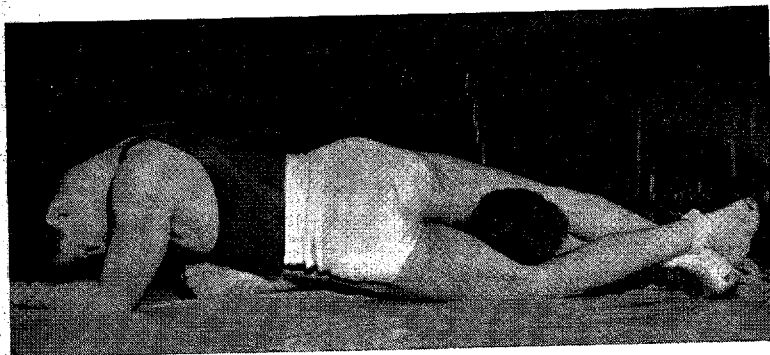

No. 13—ILLEGAL HEAD-SCISSORS.

This hold is illegal. All straight scissors on the head are illegal.

7. Scoring—Team Score

A. DUAL MEET

(1) Fall—Five points shall be scored towards the team total for each contestant who wins by a fall, default or forfeit.

(2) Decision—The decision shall count three points on the team score and shall be given to that contestant who scores the greatest number of individual match points.

(3) Draw—In case of a tie, two points shall be scored for each team.

B. TOURNAMENT. In tournament first place in each weight shall count 6 points, 2nd place, 4 points, 3rd place, 2 points and 4th place, 1 point. One additional point will be scored for each match won by a fall, default or forfeit throughout the meet.

C. MATCH SCORE POINT SYSTEM. In all matches the contestants are awarded points by the Referee in accordance with the following system.

2 Points for Take-Down (See Rule 8, Sec. 4).

1 Point for Escape (See Rule 8, Sec. 6).

2 Points for Reversal of Position (See Rule 8, Sec. 5).

2 Points for Near Fall (See Rule 9, Sec. 2).

1 Point for Predicament (See Rule 9, Sec. 3).

1 Point Time Advantage* (See Rule 8, Sec. 2). For each full minute of net accumulated time in the advantage position with two points the maximum to be so awarded for the match.

Penalties (See Penalty Chart).

* Points for time advantage shall be placed on score board before the Referee indicates the winner.

SUMMARY OF SCORING

Individual Match	Dual Meet	Tournament
2 Pts. take down	5 Pts. fall	6 Pts. 1st place
1 Pt. escape	5 Pts. default or forfeit	4 Pts. 2nd place
2 Pts. reversal	3 Pts. decision	2 Pts. 3rd place
2 Pts. near fall	2 Pts. draw	1 Pt. 4th place
1 Pt. predicament		1 Pt. for fall at any time in tournament
		1 Pt. time advantage for each net minute with 2 Pts. as the maximum.

RULE 10—INFRACTIONS

1. **Illegal Holds.** Any hold shall be allowed except the hammerlock above the right angle; the twisting hammerlock; front headlock; the straight head scissor (even if the arm is included); over-scissors; flying mare with the palm up; full (double) nelson; strangle holds; all body slams; toe holds; the bending, twisting or forcing of any limb or joint beyond its normal limits of movement, or any hold used for punishment alone.

A. Contestants may grasp all four fingers in an effort to break a hold, but pulling back the thumb or one, two or three fingers is illegal.

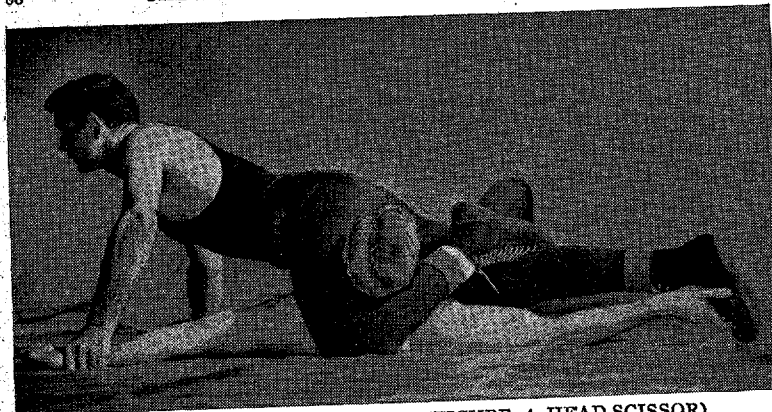

No. 14—LEGAL HEAD-SCISSORS (FIGURE 4 HEAD-SCISSOR).
The straight head-scissor is illegal. The figure 4 Head-Scissor is considered legal when taken as shown above, with the hold on either side of the face.

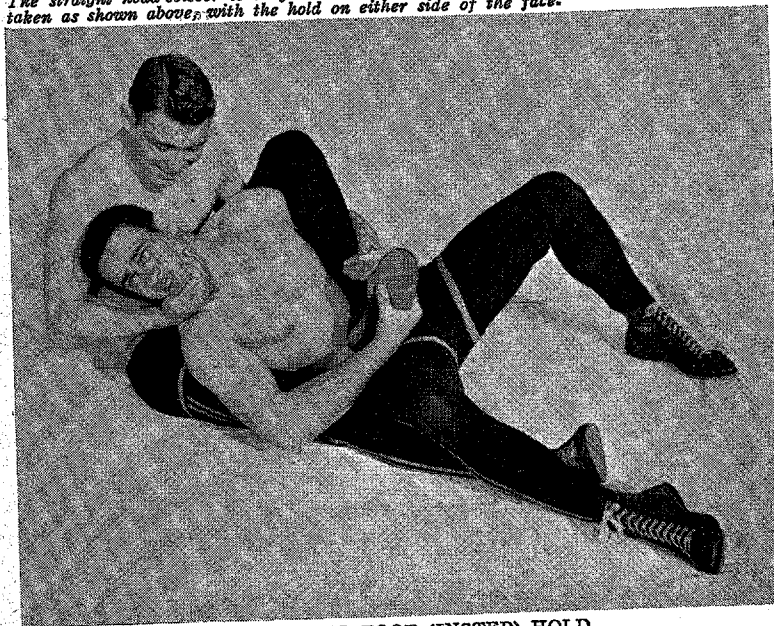

No. 15—LEGAL FOOT (INSTEP) HOLD.
The defensive wrestler is allowed to grasp instep, heel or ankle to break such holds as body-scissors, leg-ride, etc., provided the foot is not drawn up to the point where, in the opinion of the Referee, it endangers knee or hip-joint.

B. ALL SLAMS ARE ILLEGAL. The term "slam" is interpreted as lifting and bringing an opponent to the mat with unnecessary roughness. In the standing position the slam is usually preceded by a pick-up. The slam can also be accomplished by either top or bottom contestant while on the mat.

The person doing the lifting is responsible for his opponents safe return to the mat. A forceful trip is not interpreted as an illegal slam providing the defensive wrestler is not lifted completely off the mat.

C. The third violation for illegal hold shall be grounds for disqualification, regardless when the offense occurs.

2. **Unnecessary Roughness.** Intentional striking, gouging, kicking, hair pulling, elbowing or anything that endangers life or limb shall be grounds for disqualification.

In the application of the latter part of the above rule all Referees, Coaches and Contestants should understand that any and all holds used in such a way as to endanger life or limb are illegal and all Referees should be on the alert to stop, if possible, all holds that in their opinion are likely to result in endangering of life or limb before real injury does occur.

It should also be understood that no contestant should ever be put in a position where he must forfeit a neutral position, a position of advantage or a fall because of danger to life or limb, and the Referee should promptly stop any and all holds which in his opinion may so result. (See Sec. 1)

Any holds over the mouth, nose, eye or front of throat shall not be permitted. Pressure from side of hand or forearm or wrist is considered a hold and is therefore barred.

An over scissors or a leg hooked over the top toe of an opponent's body scissor is illegal. The offensive wrestler should not be penalized when the defensive wrestler turns the offensive wrestler's legal hold into an illegal hold. If a legitimate hold is forced to such an extent as to endanger a limb or it becomes a punishing hold, the Referee should stop the match and require the hold to be broken. The match shall be resumed with the contestant who had the advantage in the referee's position behind with the offender punished the same as though it were an illegal hold.

3. **Potentially Dangerous Holds.** The double wristlock and chicken wing become illegal when forced into a twisting hammerlock position. A Referee should be in position to see these holds and anticipate the danger of injury and if possible caution the contestant before an injury occurs. The double wristlock is legal if the direction of the force is perpendicular to the long axis of the body. It is illegal if the force is applied parallel to the long axis of the body. The same applies to the use of the chicken wing.

Injuries are sometimes caused by lack of knowledge on the part of contestant of such holds as double wristlock, keylock, overhead double barlock, and other potentially dangerous holds (which may cause injury when used legally). Contestants should have a knowledge of the dangers of these holds and a knowledge of the blocks for them.

4. **Technical Violations.** The interlocking of fingers, hands or arms around body or legs by the offensive contestant while on the mat is a technical violation.

A. This has reference only to the wrestler in the position of advantage on the mat, and does not apply when the defensive man has gained his feet or when the lock is used as a pin hold.

B. The Referee shall not call this violation when the defensive man is in the process of a reversal. The defensive man is allowed to complete the re-



No. 16—ILLEGAL TOE HOLD (ALSO TWISTING KNEE LOCK WHICH IS MORE DANDEROUS THAN TOE HOLDS).

All toe holds, regardless of the degree to which the leg is twisted are illegal under these rules. Any pressure against the knee joint as shown by the above illustration constitutes an illegal hold.



No. 17—OVER-SCISSORS (AN ILLEGAL HOLD).

The over-scissors is barred entirely under these rules because it is only a punishing hold and is of no value unless defensive contestant who uses it is allowed to force the hold, which thereby endangers the ankle and knee of his opponent.

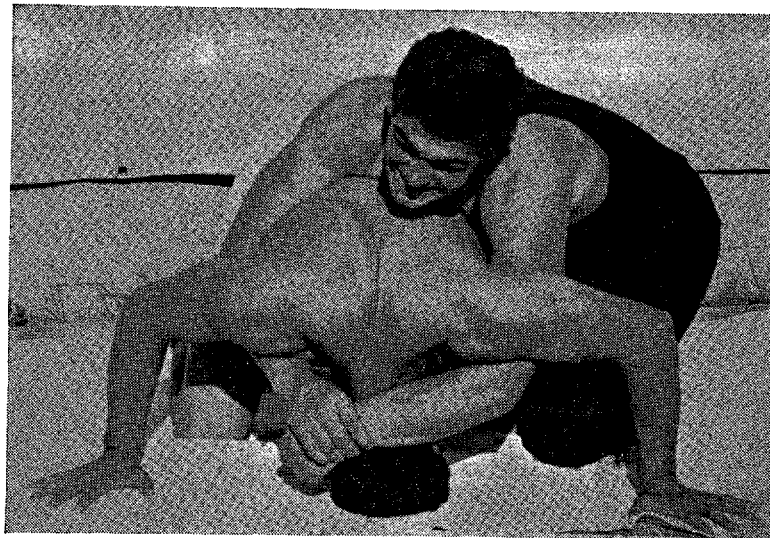

No. 18—FULL NELSON.

This hold needs no explanation. Most of the difficulty has arisen when the three-quarter is confused with the full nelson. In the full nelson the aggressor places both arms under his opponent's arms and clasps his hands or wrists on the back of his opponent's head. This is dangerous and is barred.

versal provided he does so in one continuous maneuver. If the defensive man fails to complete the reversal after an opportunity to do so then the Referee will stop the match and award the penalty.

C. Interlocking of fingers, hands or arms is permitted when the defensive man is standing. The touching of the defensive man's fingers or hands to the mat is not considered a change in this position, unless they are used as supporting points, in which case the offensive contestant is allowed reaction time to release the hold. Touching the hands to the mat to obtain a release is considered unsportsmanlike and the Referee shall not award the penalty.

D. The leg or legs may be held with both hands or arms in order to block an attempted escape. After the action ceases, reaction time is allowed for the release of the leg hold.

E. A wrestler may use both hands or arms around his opponent's leg or legs in scoring a take-down; but he must change to some legal hold after the advantage is awarded.

F. It is a violation to leave the mat without receiving permission to do so from the referee.

G. Delaying the match such as straggling back from out of bounds and unnecessary changing and adjusting of equipment is a technical violation.

H. INTENTIONALLY PUSHING DEFENSIVE MAN OFF MAT. If a contestant intentionally pushes his opponent off the mat to keep him from getting clear or going behind, the Referee shall bring both men to their feet at the center of the mat if he believes this illegal action has simply prevented the defensive

wrestler from getting free; but if he believes the defensive wrestler would have gone behind his opponent had the illegal action not occurred, he shall give the defensive wrestler the offensive position in "referee's position on the mat." Points awarded according to position given.

I. **STALLING NEAR THE EDGE OF THE MAT.** If a contestant persists in taking a position near the edge of the mat for the purpose of going off the mat or of allowing his opponent to push him off the mat when the opponent makes an effort to go behind him, the contestant shall be brought to the center of the mat and the offender warned; if he has not been already warned in another position. If he has been warned a penalty is inflicted, if this is first warning wrestlers may continue wrestling taking heed of the warning. (See Penalty Chart for Penalty.)

J. **LEAVING THE MAT TO PREVENT CAPTURE.** If in the opinion of the Referee a contestant intentionally runs, slides, crawls or rolls off the mat to prevent his opponent from going behind, the Referee shall immediately give his opponent the "referee's position behind" (See Penalty Chart). Points are awarded according to position given.

No penalty is provided if Near-Fall or Predicament points are awarded. It is considered a violation if a contestant in a body scissors intentionally goes off the mat to have the hold released.

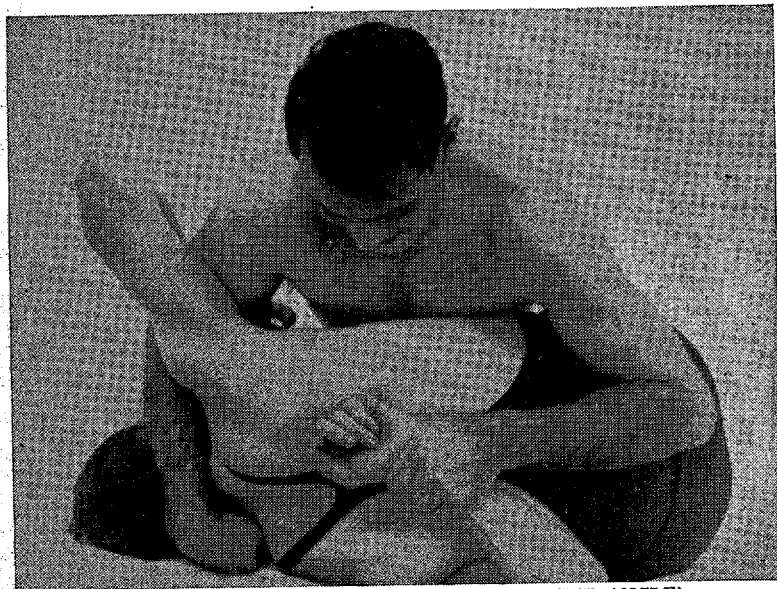

No. 19—ILLEGAL HAMMERLOCK (ABOVE RIGHT ANGLE).

The hammerlock is a legal hold, provided the arm is not bent above the right angle (i.e., provided that the arm is not carried above the small of the back); and provided, further, that the hand is not forced out away from the body, making it a twisting hammerlock. In this illustration the arm is carried distinctly above the right angle and is dangerous.

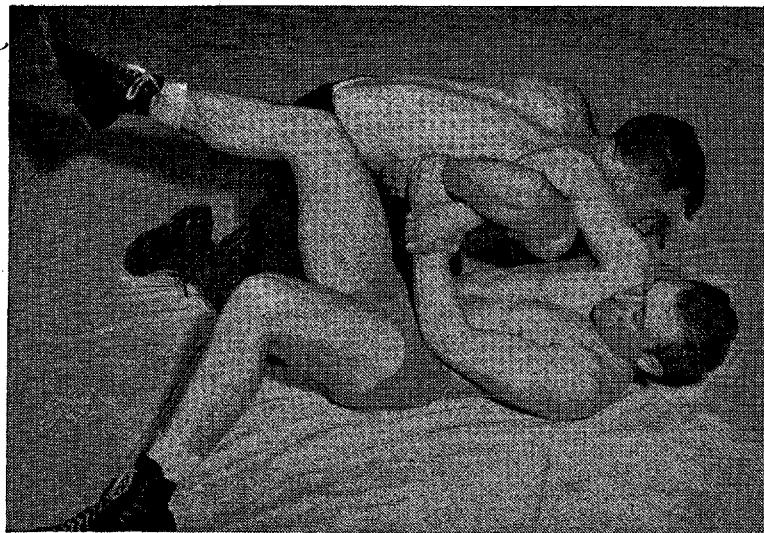

No. 20—LEGAL DOUBLE WRISTLOCK ON THE MAT.

The double wristlock on the mat is legal if the direction of the force is perpendicular to the long axis of the body.

K. The use of oil or greasy substance which cannot be removed completely and quickly, shall be grounds for disqualification. The Referee of the meet shall be the judge.

L. If the conduct of a coach or contestant becomes abusive or interferes with the orderly progress of the match, the Referee shall give one warning and for a repeated infraction the home management is responsible for their removal from the premises.

5. Stalling.

A. There shall be only one warning for stalling regardless of the position.

B. Penalties are cumulative throughout the match regardless of the position in which they occur and the second and third infractions shall be penalized as indicated on Penalty Chart. The Referee in each instance shall stop the bout and warn or penalize the offender and be sure timers and scorers are notified.

C. **NEUTRAL POSITION.** Contestants must make an honest attempt to secure a take-down regardless of the time, or score of the match.

A contestant who continually avoids contact with his opponent by staying outside the circle is stalling.

A contestant may leave the circle to maneuver for position provided he continues his attempt to gain an advantage.

D. **OFFENSIVE POSITION.** A contestant must make an honest attempt to secure a fall. Repeated take-downs and deliberately turning loose one's opponent shall be interpreted as stalling.

Penalty Chart

MOST FREQUENT OFFENSES

INFRACTION	POSITION OF OFFENDER	PENALTY FIRST	PENALTY SECOND	PENALTY THIRD	RULE 10 SECTIONS
Abusive language or conduct by coaches, contestant or spectators		Warning	Removal from premises by home management		6
Oily or greasy substance on body			Disqualify if it cannot be removed completely		5
Illegal Hold and/or unnecessary roughness	Neutral	2 pts. N.C.	2 pts. T.D. Final Warning	Disqualify	
	Advantage	2 pts. N.C.	2 pts. R. Final Warning	Disqualify	1 and 2
	Defensive	2 pts. N.C.	2 pts. N.C.	Disqualify	
TECHNICAL VIOLATIONS:					
Interlocking of hands around body holding leg or legs with two hands or arms	Advantage	1 pt. N.	1 pt. N.	1 pt. N.	4A 4B
Leaving mat without permission or delaying match (Rule 11, Sec. 3)	Advantage	Warning	1 pt. N.C.	1 pt. N.C.	4F
Taking position near edge of mat	Neutral	Warning	2 pts. T.D.	2 pts. T.D.	4I
Stalling (only one warning throughout match). Rule 10, Sec. 5	Neutral Advantage Defensive	Warning (1 Warning throughout match)	2 pts. T.D. 1 pt. N. 1 pt. N.C.	2 pts. T.D. 1 pt. N. 1 pt. N.C.	Rule 11, 3B Sec. 1 & 2
Intentional running, crawling or sliding off the mat or pushing, pulling or carrying an opponent off mat to prevent a change in position.	Neutral Advantage	2 pts. T.D. 2 pts. R. 1 pt. N.	2 pts. T.D. 2 pts. R. 1 pt. N.	2 pts. T.D. 2 pts. R. 1 pt. N.	4J
Intentional Going Off Mat (not given if near fall points are awarded)	Defensive	1 pt. N.C.	1 pt. N.C.	1 pt. N.C.	4J

Key: TD-takedown, R-reverse, N-neutral, NC-no change. It is suggested that this chart be incorporated in your dual meet program.

E. Merely riding an opponent and not attempting a fall is considered stalling.

F. A hold such as a headlock is not a stalling hold if, in the opinion of the Referee, the offensive wrestler has a fair chance to pin his opponent and is making a real effort to pin him.

G. DEFENSIVE POSITION. If the defensive contestant lies on his stomach and refuses to wrestle he is stalling. If a contestant intentionally crawls off the mat to prevent a maneuver by his opponent he is stalling and is penalized 1 point.

"Clamming Up" or lying on one's stomach and making no attempt to escape or reverse is stalling and shall be penalized.

RULE 11—PENALTIES

1. The infractions of the rules are penalized in accordance with the penalties as listed on the Penalty Chart (page 74).

2. In calling each penalty the Referee shall stop the match, give the hand signal for the points or warning and announce the penalty so that the contestants, scorers, coaches and spectators are aware of it.

3. Sequence of Penalties.

A. ILLEGAL HOLDS OR UNNECESSARY ROUGHNESS. Each contestant has only one First Penalty, Second Penalty and Third Penalty for illegal action

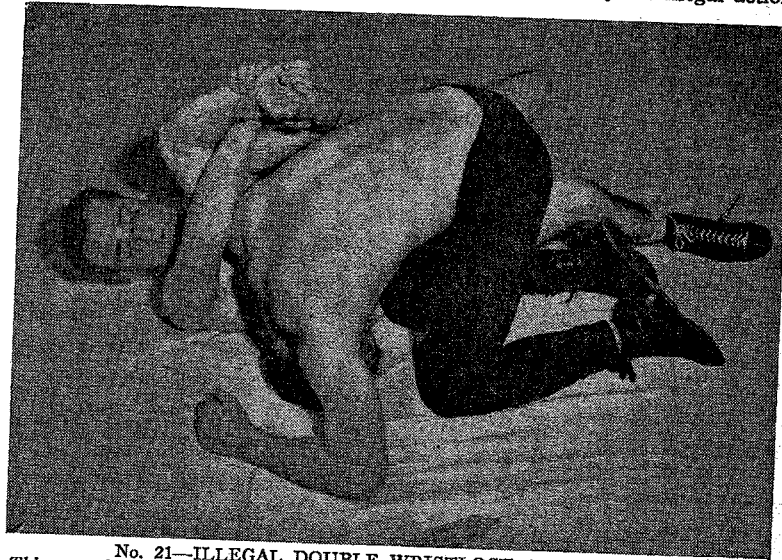

No. 21—ILLEGAL DOUBLE WRISTLOCK ON THE MAT. This cut shows double wristlock turned into a typical twisting hammerlock that will injure opponent's shoulder if the arms are forced upward, unless opponent turns with the pressure, which often he is unable to do promptly enough to prevent injury to the shoulder.

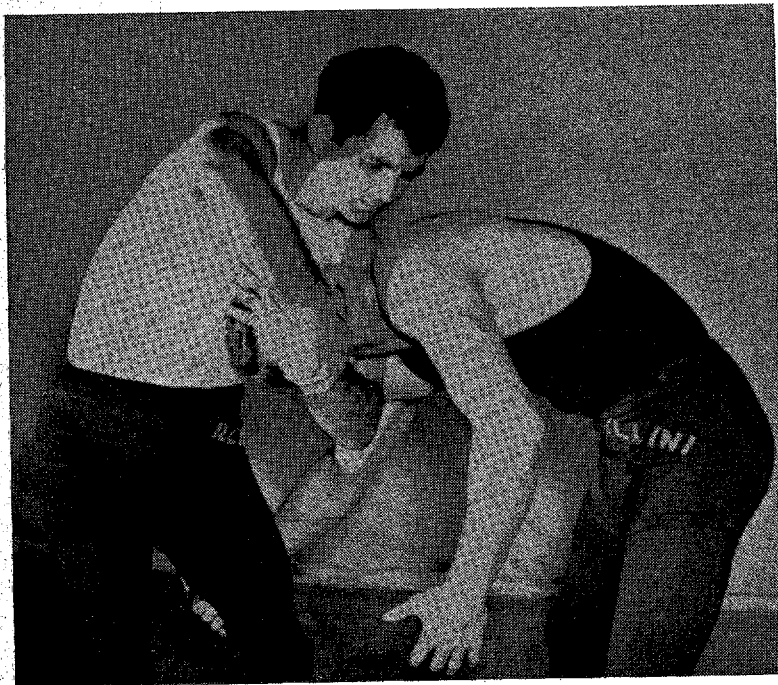

No. 22—ILLEGAL FRONT HEAD LOCK.
This cut shows how the front head lock is used to counter a leg pickup. This hold is dangerous and is illegal. Leverage as applied on the neck is illegal.

regardless of whether he is in the neutral, advantage or defensive position. He does not get two penalties from each position before disqualification. The penalties are cumulative regardless of position and the offender shall be disqualified on the third penalty when he has a series of three illegal infractions.

B. **STALLING.** Each contestant has only one First Penalty warning for stalling regardless of whether he is in the neutral, advantage or defensive position. He does not get a warning in each position. The stalling penalties are cumulative throughout the match regardless of the position in which they occur and the second and third infractions shall be penalized as indicated on the Penalty Chart.

RULE 12—INJURIES AND DEFAULTS

1. If a contestant is injured, the Referee shall allow a maximum time out of three minutes. There shall be no limit to the number of time-out periods which may be taken in any match, but the total time-out shall not exceed three minutes. If, at the expiration of the time-out, he is able to continue

wrestling, the match shall be resumed as if the contestant had gone out of bounds. (See Rule 8, Sec. 9).

If the injured contestant is unable to continue wrestling the match shall be awarded in accordance with Sections 2 and 3 of this Rule.

In the interpretation of this rule, nosebleed is not an injury, and the number and length of time out periods to be allowed is at the discretion of the Referee.

2. **Accidental Injury.** If a contestant is accidentally injured and is unable to continue the match, his opponent shall be awarded the match by fall.

3. **Injury from Illegal Hold.** If a contestant is so injured by an illegal hold that he is unable to continue, the match shall be forfeited to the injured contestant and shall be scored as a fall.

In case of an intentional attempt to injure an opponent the offender shall be disqualified.

If a contestant fails to compete in a round he shall be disqualified for the remainder of the tournament.

In other cases of disqualification the loser may continue in the consolation rounds if eligible.

RULE 13—OFFICIALS

Referee's Duties:

1. The Referee shall have full control of the meet and his decisions shall be final and without appeal.

2. Before the contestant comes to the mat the Referee shall:

A. Inspect contestants for presence of oils or greasy substances, rosin, objectionable pads, improper clothing, finger rings, long finger nails, etc.

B. Clarify the rules with coaches and contestants.

C. Advise contestants to report to edge of the circle at the center of the mat opposite each other ready to wrestle.

D. The referee is responsible for the proper seating of timekeepers and scorers at the officials table as follows:

Home Team Assistant Timekeeper	Visiting Team Assistant Timekeeper	Head Timekeeper	Visiting Team Scorer	Home Team Scorer
--------------------------------------	--	--------------------	-------------------------	---------------------

3. Instruct the head timekeeper that he is:

A. In charge of assistant timekeepers, and scorers, and should be constantly checking their activities at all times.

B. Responsible for keeping the over-all time of the match.

C. Responsible for recording accumulated time-outs for injury.

D. Responsible for recording which contestant has the position of advantage at the start of the second period.

E. Responsible for informing the Referee, only after an imminent situation has passed, whenever there is disagreement by the official scorers and/or timekeepers.

F. Responsible for assisting the Referee in determining whether a situation occurred before or after the termination of a period.

G. Responsible for calling the minutes to the referee, contestants, and spectators in each match. The last minute shall be reported at fifteen second intervals.

Note. The Home Institution shall provide each timekeeper with an accumulative time clock for recording the time during the match. The head timekeeper shall be provided with two extra accumulative time clocks for recording time out in case of injury to the contestants. The head timekeeper shall also be provided with a gong, horn, or bell.

4. Instruct the assistant timekeepers that they are responsible for:

A. Recording the accumulative time advantage of the contestants, to whom they have been assigned when indicated by the Referee.

B. Constantly checking each others time advantage recording.

C. Constantly checking the head timekeepers time recording.

D. Showing the Referee the stop clock recording of the time advantage each contestant has accumulated at the end of the match.

5. Instruct the scorers that they are responsible for:

A. Recording points scored by both contestants when signaled by the referee.

B. Constantly checking each others score reading.

C. Immediately advising the head timekeeper when they are in disagreement regarding the score.

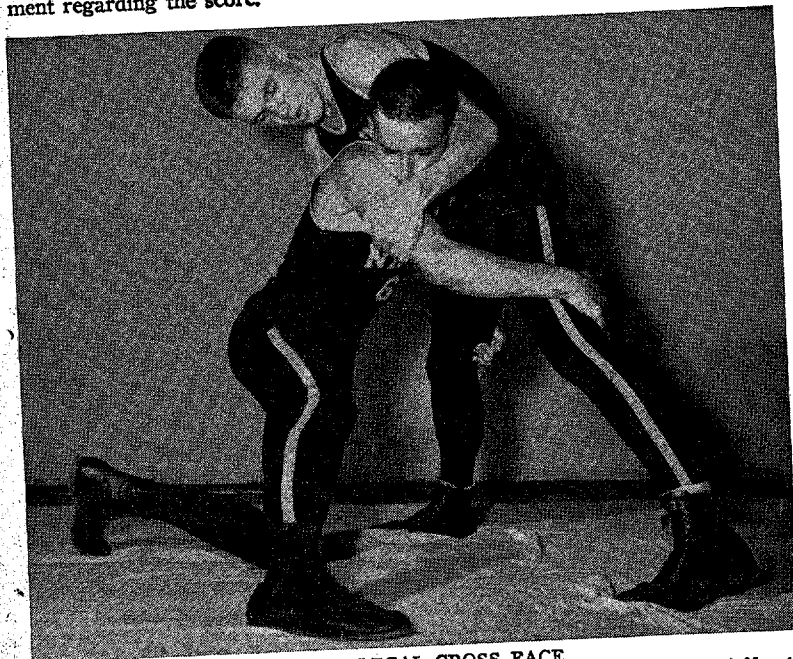

No. 23—A LEGAL CROSS FACE.

It is an effective and legal block for the double leg pickup by the opponent of No. 6.

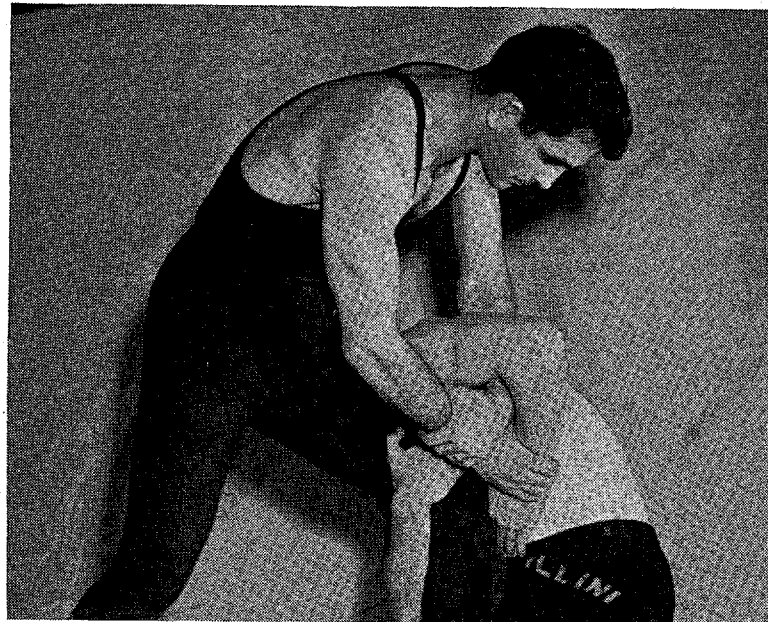

No. 24—LEGAL DOUBLE WRISTLOCK FROM THE STANDING POSITION.
This shows the start of a legal double wristlock from the standing position. Notice the position of the hands of the contestant that is standing.

D. Keeping the score board operator continually advised of the official score during each match.

E. Showing the Referee the scorecard at the end of each match.

6. Before the dual meet starts call the team captain to the center of the mat for the toss of the coin to determine the choice of position at the start of the second period. (Rule 7, Sec. 4)

7. The Referee will use the Wrestling Officials Signals.

8. The Referee shall notify the timekeepers as follows:

A. When the match starts.

B. When the match is stopped for any reason.

C. When the match is resumed.

D. When time advantage begins for a contestant.

E. When time advantage stops for a contestant.

F. Whenever time is involved in any situation occurring in the match.

9. The Referee shall notify the scorer.

10. The Referee should anticipate difficult positions on the edge of the mat and prevent them by stopping the match, and resume wrestling at the center of the mat, as in the case of an off-mat decision.

11. The Referee shall be firm in enforcing the letter and the spirit of the rules and penalize consistently any repeated infractions. He must enforce

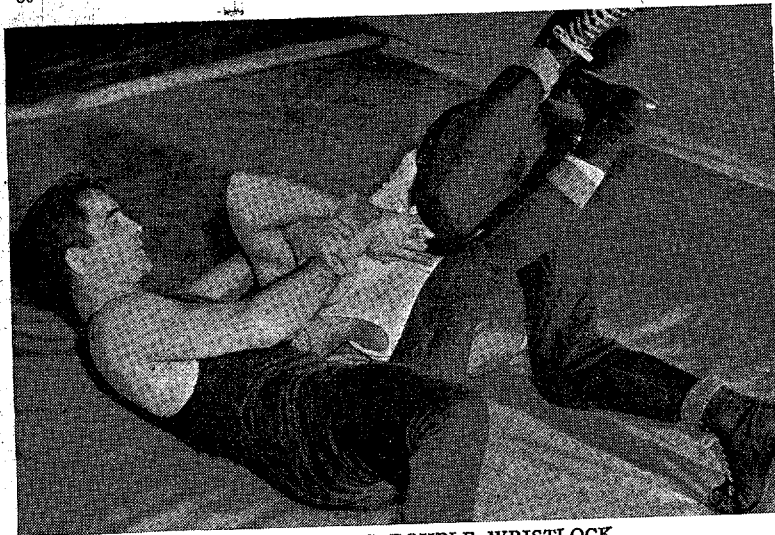

No. 25—STANDING DOUBLE WRISTLOCK.
Notice position of each contestant's feet and hands.

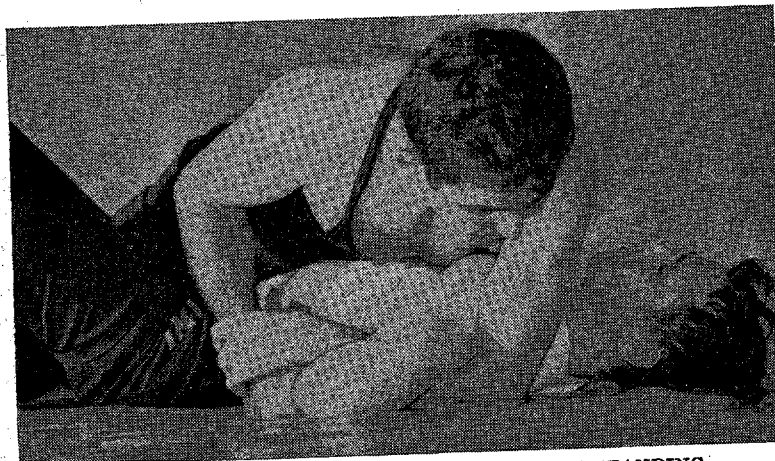

No. 26—DOUBLE WRISTLOCK SERIES FROM STANDING.
Finish of a legal double wristlock from standing on the mat.

vigorously and promptly the penalties for stalling, etc., as provided in Rule 11. On each penalty the Referee shall stop the match and award the penalty in the prescribed manner. (See Signals for Referees)

12. The Referee shall caution the user of a potentially dangerous or illegal hold in order to prevent possible injury. Such holds should be stopped by the Referee, if possible, before the hold reaches the dangerous stage.

13. The Referee is instructed *not* to put his hand "under the shoulders" of a contestant unless *absolutely necessary* to determine a fall.

14. The Referee should meet promptly, in a spirit of good sportsmanship, any situation developing unexpectedly.

15. If the conduct of a coach, contestant, or a spectator interferes with the orderly progress of the match, the home management shall be responsible, at the request of the Referee, for the removal of the offender from the premises.

16. At the end of each match the Referee shall order the contestants to shake hands and return to their respective corners on the mat. He shall then check the timekeeper and scorers records to decide the winner. He shall call the two contestants together have them shake hands and raise the right hand of the winner. If the match is a draw the Referee will raise the right hand of both contestants.

Note 1. If in the opinion of the Referee there is an error in the recordings of the timekeepers and/or scorers, the referee shall correct the error and render his decision accordingly.

Note 2. In championship matches two of the Referees shall act as judges and their vote together with the vote of the Referee shall determine the winner when the point scores are even.

Note 3. In tournaments when two officials are taking turns working on the same mat, one may act as a consultant in case of a tie match.

RULE 14—NOTIFICATION AND AGREEMENT OF MEETS

1. **Equal Rights for Visiting Teams.** All modifications of rules of competition, "ground rules," etc., proposed by the home manager, must be submitted to the manager of the visiting team, or teams, a sufficient length of time before date of meet for agreement to be reached on same, and no such action is binding unless approved by the visiting team or teams.

2. In dual meets the selection of a Referee and the maximum weighing-in time shall be mutually agreed upon at least ten days prior to date of meet.

Note. In case the Coaches concerned are unable to agree on a shorter maximum weighing-in time than the five hours specified as the maximum in these rules, it is understood that the maximum amount of time as specified in the rules shall hold.

3. The home management shall notify visiting teams at least ten days prior to date of meet the exact time and place of match.

Wrestling Officials' Signals

RULE 15

THE USE OF THE WHISTLE.

The majority of the officials wind the string attached to the whistle around their hand and hold the whistle with the thumb and index finger. Others loop the string around the neck and carry the whistle in their mouth at all times.

TIMER'S TABLE

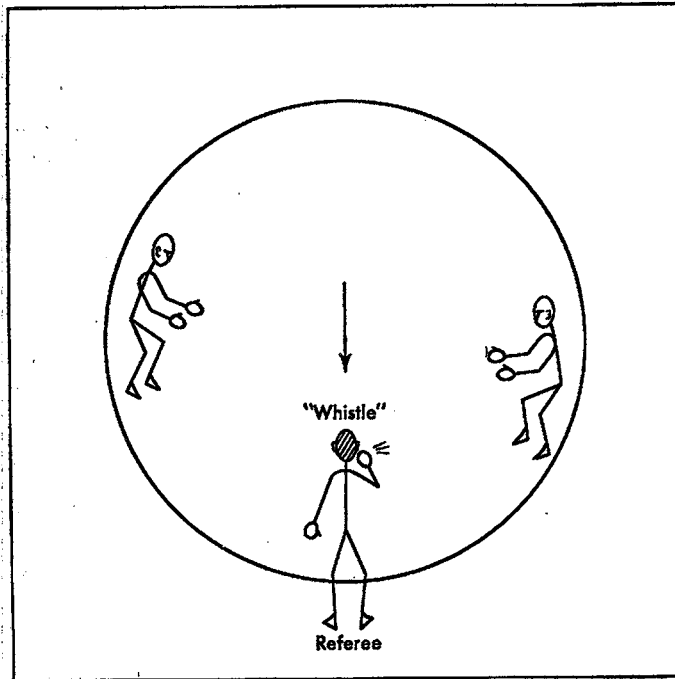

Fig. 1. STARTING OR RESUMING A MATCH STANDING.

A match shall be started by the Referee's whistle. Whenever the match is started or resumed with contestants in neutral position on their feet, the contestants shall be within the edge of the ten-foot circle. The Referee shall face the timer's table and blow the whistle.

TIMER'S TABLE

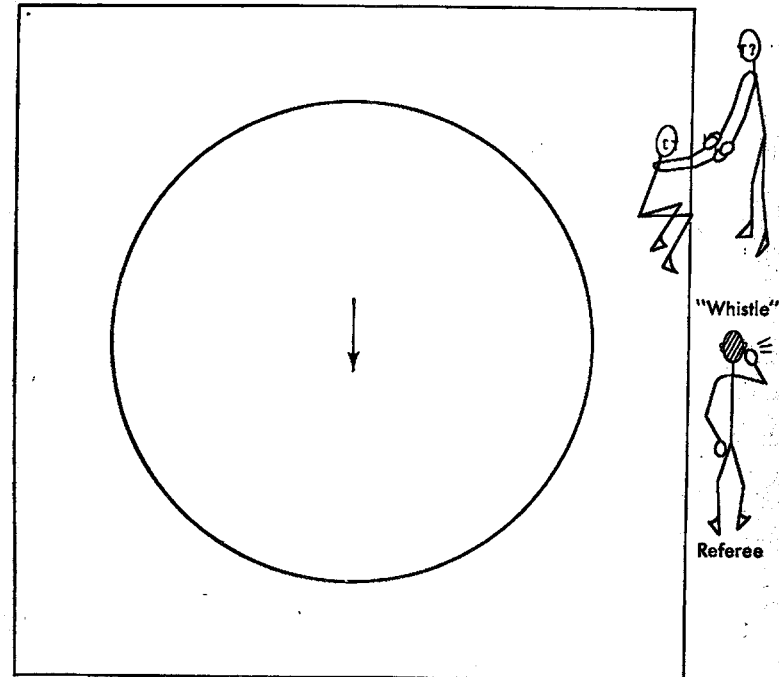

Fig. 2. STOPPING AND RESTARTING THE MATCH.

When contestants are "off the mat" the Referee shall stop the match by sounding the whistle, bring the contestants to the center of the mat and restart the match.

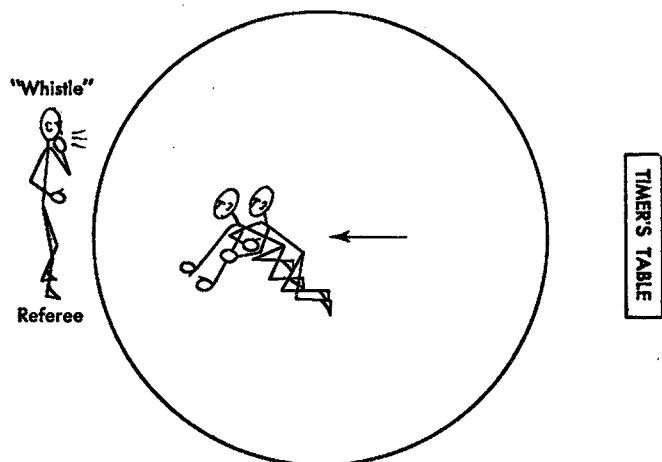

Fig. 3. BEGIN WRESTLING ON MAT.

The Referee should be eight to ten feet in front of wrestlers, facing timer's table. When the wrestlers are in the proper position the Referee blows the whistle.

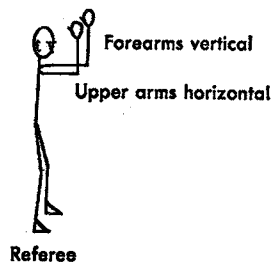

Fig. 4. NEUTRAL POSITION (STANDING).

Upper arms front, horizontal; both forearms vertical, hands extended.

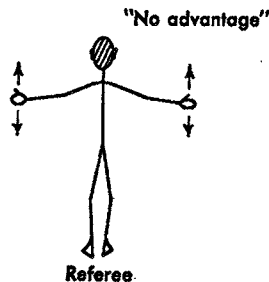

Fig. 5. NEUTRAL POSITION (NO ADVANTAGE).

On mat—Both arms extended sideward slightly below the horizontal, palms down; move hands back and forth and at the same instant verbally announce "No Advantage."

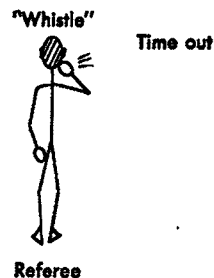

Fig. 6. "TIME OUT."

Blow whistle to stop wrestlers, then announce "Time Out." Next explain to timers the reason for taking time out.

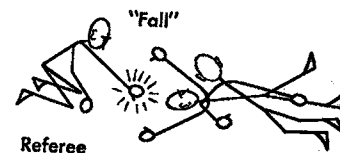

Fig. 7. FALL CALLED.

Quickly strike mat with palm of one hand and at the same instance verbally announce, "Fall." Do not slap wrestler on back. The Referee is not to put his hand under shoulders of a contestant unless absolutely necessary to determine a fall.

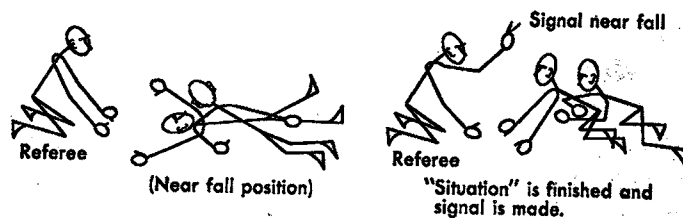

Fig. 8. DECLARING NEAR FALLS AND PREDICAMENTS.

After the "situation" is finished extend one arm vertically indicating with fingers the number of points awarded.

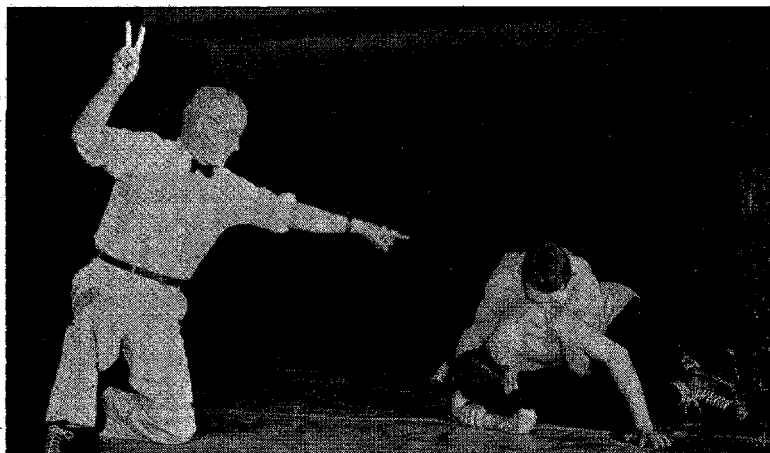

Fig. 9. POSITION OF ADVANTAGE.

One arm and index finger pointing to wrestler receiving advantage. At the same time verbally announce "Advantage" and name the institution which offense represents. Raise the opposite hand to or near vertical position indicating with fingers the number of points awarded.

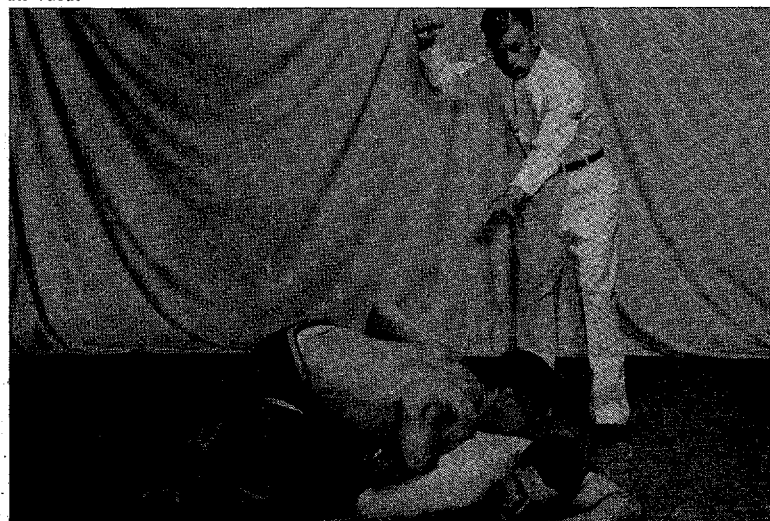

Fig. 10. WARNING FOR STALLING.

The right hand is raised and the fist doubled with the index finger of the left hand pointing toward the offender. The referee shall notify the offended contestant verbally at the same time the signal is given.

High School Wrestling Rules

The NCAA Rules shall apply with the following exceptions:

1. **Eligibility.** Contestants shall be eligible under the rules of the High School Athletic Association of the State in which their school is located.

2. **Weight Classification.** Competition shall be divided into weight classes as follows:

103 lbs.	138 lbs.
112 lb.	145 lbs.
120 lbs.	154 lbs.
127 lbs.	165 lbs.
133 lbs.	Unlimited.

Beginning January 1st and continuing until February 1st, two additional pounds will be allowed in each weight class. Beginning February 1st and continuing for the remainder of the season, one additional pound shall be allowed in each weight class. This will make a net increase of three pounds beginning the 1st of February.

Additional weight classes may be officially included in the weight classification provided they are adopted by the individual state athletic associations. Interstate dual meets shall be contested in the original 10 weights.

3. **Weighing In of Contestants.**

A. **DUAL MEETS.** Contestants may weigh in a maximum of one hour and a minimum of one half-hour before time the meet is scheduled to begin. (By mutual consent of the competing schools the college regulations may be followed.)

B. **TOURNAMENTS.** Each day of the tournament, contestants may weigh in a maximum of five hours and a minimum of one hour before the meet is to begin, with one pound allowance to be given each day over the weight limit of the previous day as in college rules.

Note. Changes in weighing in time may be made by the individual state associations.

4. **Length of Matches.**

A. **DUAL MEETS.** These matches shall be six minutes in length divided into three periods of two minutes. No rest is allowed. These matches shall be conducted in the same manner as dual meets and first-place matches in tournaments under college rules. If a match results in a tie, it shall be decided in accordance with the last sentence of College Rule 9, Section 6A.

B. **TOURNAMENT.** These matches shall consist of three periods of two minutes each, conducted in the same manner as third-place matches under college rules. If a match results in a tie, it shall also be decided in accordance with the last sentence of College Rule 9, Section 6B.

C. No contestant shall be required to wrestle two matches in any tournament with less than a one (1) hour rest between such matches.

5. **Illegal Holds.** Illegal holds shall be the same as the holds barred in College Rule 10.

Penalties. See Penalty Chart.

Index to Rules

	Rule	Sec.	Page		Rule	Sec.	Page
Byes	6	5	57	For Third Place in tour-	7	3	61
Communicable Disease	5	4	57	naments	7	3	61
Compete in One Class Only	2	2	53	Intermission Between Pe-	7	2	61
Costumes	3	2	54	riods	3	1	53
Decisions	9	6	65	Mats	9	2	65
Matches	9	6	65	Near Falls	9	2	65
Defaults	12	3	77	Notifications and Agree-	14	..	81
Distinguishing Emblems	3	3	55	ments	13	..	77
Drawings and Elimination	6	6	57	Officials	13	..	77
For Third Place	6	7	59	Referee	13	1	77
Graphic Illustration of	6	6	58	Timekeepers	13	3	77
Seeding	6	3	57	Penalties	11	..	75
Eligibility	1	..	53	Off Mat to Prevent Fall	10	4	72
Falls	9	..	64	Off Mat Intentionally	10	4	72
Pin	9	1	64	Pushing Defensive Man	10	4	71
With Part of Body Off	9	2	64	Off Mat	10	4-5	72
Mat	9	2	64	Stalling	10	4-5	72
Holds—Illegal	10	..	67	Point System	9	7	67
Bending of Fingers	10	1	67	Position of Advantage	8	3	63
Body Slams	10	1	69	Referee's Position on Mat	8	1	61
Double Wristlock	10	3	69	Representation	2	..	53
Full Double Nelson	10	1	67	Roughness—Unnecessary	10	2	69
Hammerlock Above Right	10	1	67	Butting	10	2	69
Angle	10	1	67	Elbowing	10	2	69
Holds Over Mouth, Nose,	10	2	69	Gouging	10	2	69
Eyes or Throat	10	2	69	Hair Pulling	10	2	69
Interlocking of Arms	10	4	69	Kicking	10	2	69
Interlocking of Fingers	10	4	69	Strangling	10	2	69
Interlocking of Hands	10	4	69	Striking	10	2	69
Over-Scissors	10	1	67	Seeding	6	3	57
Strangle Holds	10	1	67	Scoring	9	..	64
Twisting of Fingers	10	1	67	Tournaments	9	7	67
Twisting Hammerlock	10	1	67	Dual Meets	9	7	67
Toe Holds	10	1	67	Point System	9	7	67
Injuries	12	..	76	Spectators' Behavior	13	5	81
Accidental	12	2	77	Stalling	10	5	73
From Illegal Hold	12	3	77	Weighing-In	5	1	56
Intermissions	7	2	61	Weight Classification	4	1	55
Matches—Length of	7	..	61	Weight Allowance	5	2	57
For First Place	7	1	61	Failure to Make	5	3	57

DRINK
Coca-Cola
REG. U.S. PAT. OFF.
"Coke"
REG. U.S. PAT. OFF.

*Ask for it either way
... both trade-marks
mean the same thing.*

OFFICIAL

WITH AMERICA

Spalding—for more than three-quarters of a century—has manufactured equipment used by American athletes and sports-minded millions. Consultation with outstanding athletes and sports experts and its endless research have made the name SPALDING a byword in American sports.

IT'S OFFICIAL
IF IT'S

SPALDING

SPALDING SETS THE PACE IN SPORTS

